

26  
**SAAB 99**

10712 MILES

**OWNER'S MANUAL**

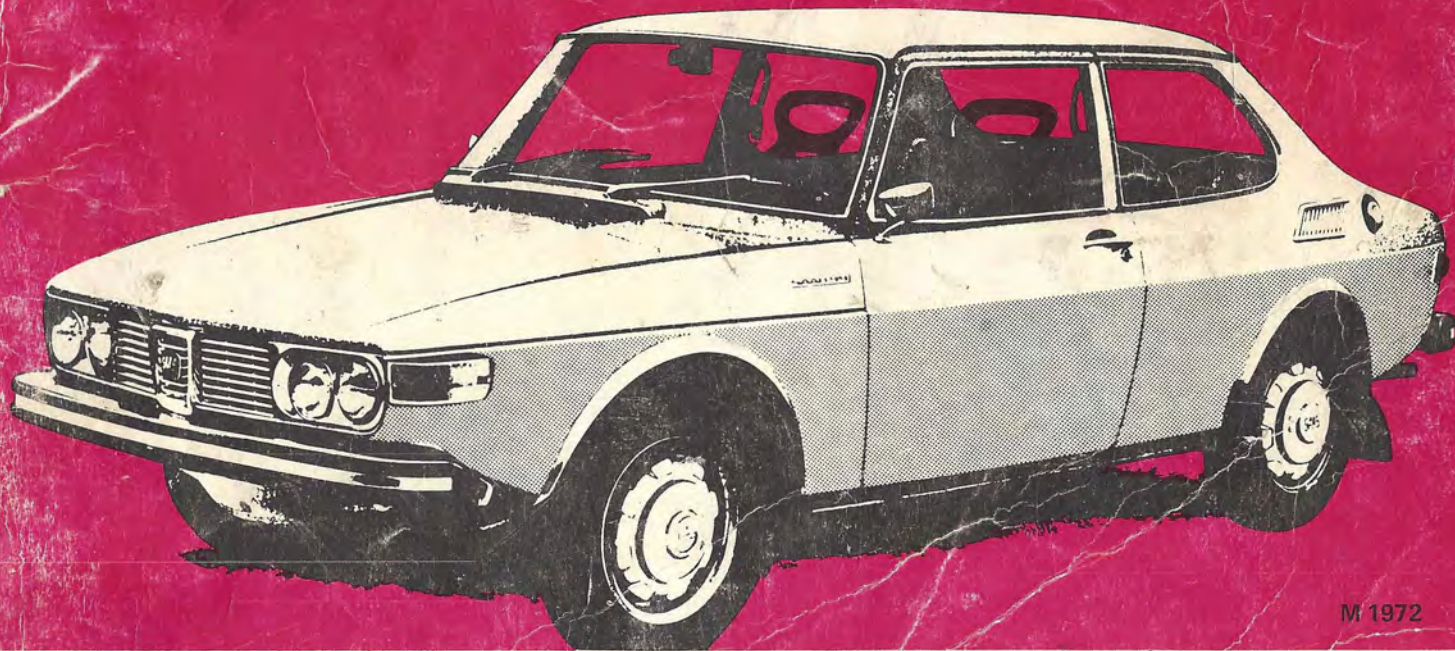

M 1972

# SAAB 99

## Owner's Manual

---

Saab—Scania of America, Inc.

100 Waterfront Street, New Haven, Conn. 06506

1st Edition

## CONTENTS

Foreword	3
This is Saab-Scania	4
Chassis number etc.	6
<b>Controls and instruments</b>	
Keys	7
Door locks	7
Trunk lock	8
Glove compartment lock	8
Ignition switch and gear lever lock	9
Controls and instruments	11
<b>Interior fittings and seats</b>	
Interior lighting	18
Ashtrays	19
Rear view mirrors	19
Front seats	20
Back seat — trunk	22
Safety belts	23
<b>Driving instructions</b>	
Starting the engine	24
Manual transmission	25
Automatic transmission	26
Gear selector lever	26
Brakes	28
Tires	28
Steering characteristics	28
Break in	29
Driving economy	29
Driving on slippery roads	29
A few useful hints	30

## Maintenance

Fuel	32
Engine oil	32
Transmission oil	33
Cooling system	33
Brakes	33
Battery	33
Tire pressures	34
Windshield washers	34
Lubrication instructions, manual transmission	35
Lubrication instructions, automatic transmission	36

## Description and care

Engine	40
Fuel system, injection engine	42
Fuel system, carbureted engine	44
Cooling system	47
Clutch, manual transmission	49
Manual transmission and differential	49
Automatic transmission	50
Brake system	51
Steering mechanism	54
Suspension	54
Wheels and tires	55
Jack and spare wheel	56
Electrical system	57
Bodywork	64
Trouble shooting, carbureted engine	66
Trouble shooting, injection engine	68

Driving with a trailer	70
Motoring abroad	70
Technical data	71

SEE ALSO ALPHABETICAL INDEX ON P. 76

Dear Saab Owner:

This book is the driving and maintenance manual for your Saab 99, and we suggest that you read it before you take the wheel for your first run. It is a good idea to keep the book in the car where you can consult it if the need should arise.

We strongly recommend that you follow the maintenance routine described in the accompanying Service Book. Always take your car to an authorized Saab dealer for its periodic checkups; that way you can rest assured that it is in the hands of welltrained people with the proper

equipment to do the job. Similarly, all adjustments and any necessary repairs must be carried out with the proper techniques and equipment, so always go to an authorised Saab dealer and always insist on original Saab spare parts. We must reserve the right to make changes in equipment and specifications during production without prior notice.

Yours truly,  
~~SAAB-SCANIA~~  
Automotive Group  
Fröhhättan, Sweden, August 1971

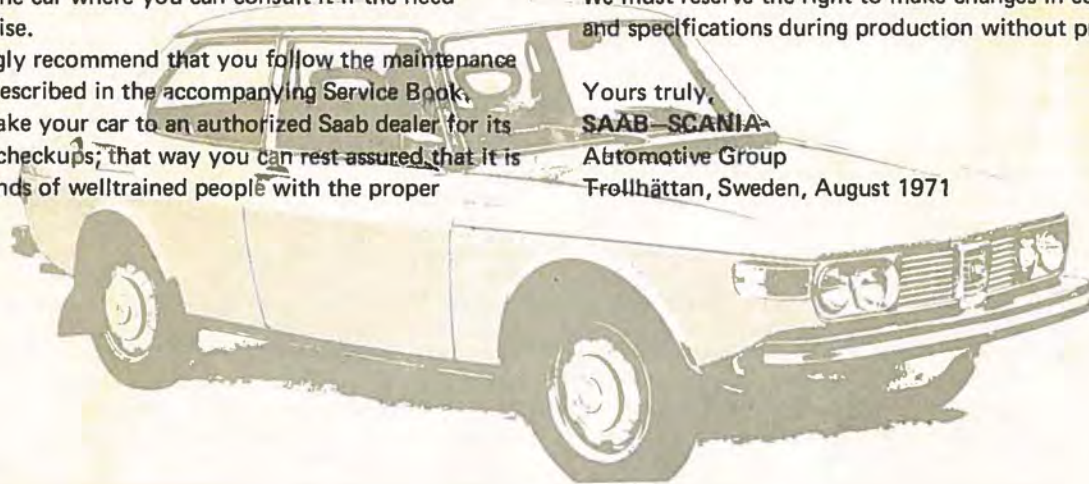

## This is Saab-Scania

Saab-Scania is a new conception within large-scale Swedish Industry — a combination of two up-to-date industrial companies with long experience and a substantial export policy. On account of the merger between Saab and Scania-Vabis in 1968 conditions have been created for a better combined utilization of the resources for research, product development, production and export.

During 1970 the company's turnover amounted to more than 3,500 million Swedish Crowns while the total number of employees was about 29,000. Saab-Scania now disposes over the largest organization in Scandinavia for advanced technical development work.

### Four Groups

From the organizational aspect the company is divided up into four product target groups with own productivity responsibility. The experiences gained by the company extend way back to 1897 when the first Swedish factory-built passenger car was manufactured that particular year in Södertälje. At the present day the Automotive Group is one of the leading manufacturers in the world of heavy diesel vehicles at the same time as the manufacture of passenger cars has expanded more and more. Considerably more than half of the total vehicle production is exported abroad. The Automotive Group is responsible for development, production and marketing of Scania products (trucks, buses, separate engines) in Sweden and for export and development and production including marketing for export of Saab passenger cars. The marketing of Saab cars in Sweden takes place through the subsidiary company Saab-Ana. Volkswagen and Porsche are marketed by the subsidiary company Svenska Volkswagen. The most important places of production within the Automotive

Group are Södertälje (manufacture and assembly of Scania trucks and engines) and Trollhättan (manufacture and assembly of Saab passenger cars). Within the Automotive Group there are also many other places of production in and outside Sweden. Among these are Uusikaupunki in Finland (assembly of Saab cars, Oy Saab-Valmet Ab), Zwolle in Holland (assembly of trucks and engines, Saab-Scania Nederland N.V.), and Gothenburg (manufacture of transmissions for Saab passenger cars).

Aircraft manufacture was officially started in 1937, but the actual activity goes right back to the year 1930. After the Second World War the Aerospace Group developed to be one of the leading European manufacturers of military aircraft and has also succeeded, in face of severe International competition, in building up several important export markets. The Aerospace Group has a substantial development and production activity within both the field of guided missiles and in respect of airborne electronics etc. The Saab-Scania Aerospace Group is the biggest defence industry in Sweden.

A thriving new departure in the Company's business is the Saab-Scania Computer and Electronics Group, which in a bare ten years has burgeoned into a vigorous Swedish computer enterprise producing equipment for administrative, technical and scientific data processing. The Group has also a division working in the medical field primarily on X-ray television and electro-medical equipment. Another division produces numerical control and process-control systems for the needs of industry.

In 1968 Nordarmatur was acquired — a company which is a leading manufacturer of valves and complete systems for control measurement and check of the majority of existing media. This company is now merged with Saab-Scania as the Nordarmatur Group. The products of this group cover a wide range, from needle valves for pressure gauges to armatures for vessels, nuclear power plants and processing industry.



The Automotive Group manufactures and markets heavy diesel vehicles and separate engines (Scania) and passenger cars (Saab). During 1970, some 73,000 cars and 14,000 trucks and buses were produced.



The most recent addition to the company's aircraft range is the Saab 37 Viggen.



Datsaab D 22 is a civil computer, which is used for both administrative and technical/scientific computer applications.



The Nordarmatur Group manufactures and markets amongst others valves for power plant. NAF wedge gate valves has been installed in the Oskarshamn nuclear power plant.

## CHASSIS NUMBER ETC.



Gearbox number, auto-  
matic transmission



Gearbox number, manual  
transmission



Engine number

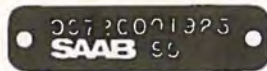
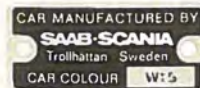

Color code and chassis  
number signs



Chassis number punched in  
car body, 2-door model  
(under back seat cushion)



Chassis number punched in  
car body, 4-door model  
(under back seat cushion)

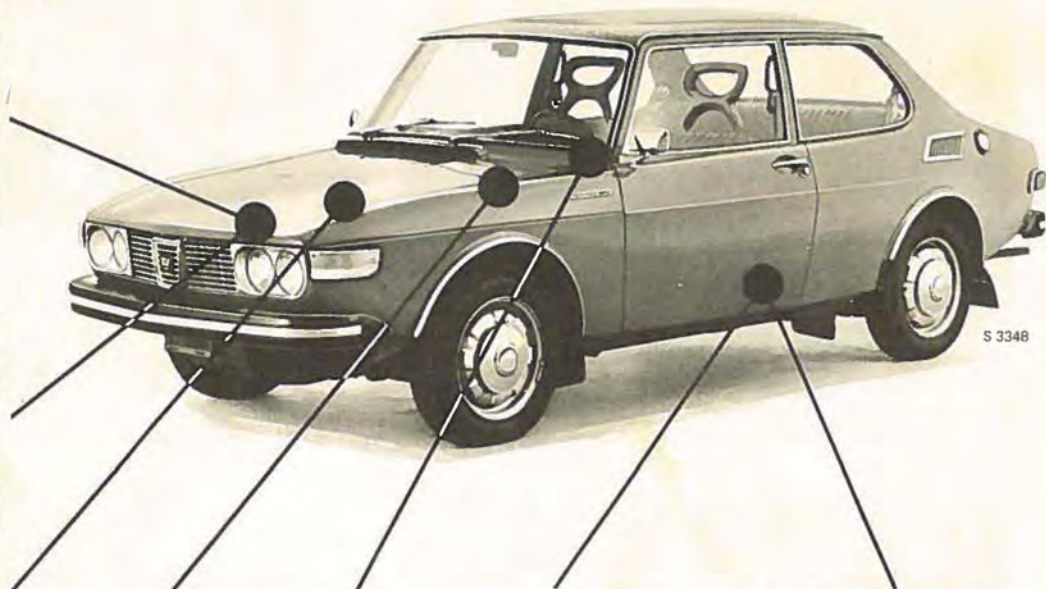



### Door lock

1. Lock
2. Unlock

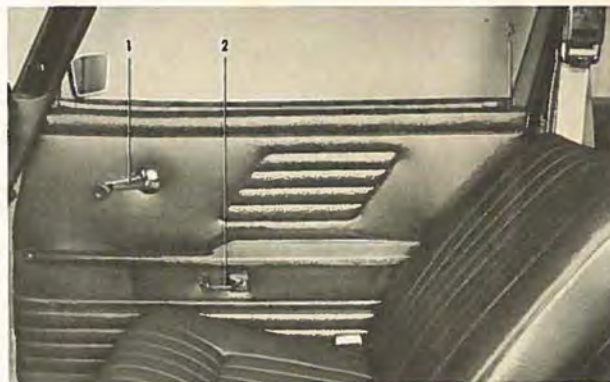

### Inside of door, 2-door model

1. Window crank
2. Inside door handle
3. Door lock button

## KEYS

Two keys are supplied with the car. Both fit the ignition switch and all locks. The serial number of the key will be found under the rubber cap.

## DOOR LOCKS

Both side doors have lockable handles. These are locked and unlocked as follows:

To lock: give the key a quarter turn forward and let it spring back to the vertical position.

To unlock: give the key a quarter turn rearward and let it spring back to the vertical position.

The doors are fitted with safety lock buttons with which they can be locked from the inside when closed.

**NOTE!** The door cannot be unlocked from the outside when the safety button is down.



## CONTROLS AND INSTRUMENTS

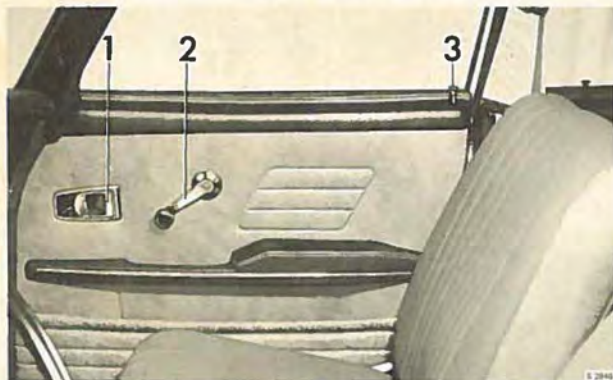

### Inside of door, 4-door model

1. Inside door handle
2. Window crank
3. Door lock button



### Trunk lock

1. Lock
2. Unlock

## TRUNK LOCK

The trunk is locked and unlocked in the same way as the doors.

(The spare wheel is carried in the trunk and the jack and tool kit are stored in a covered compartment beside the spare wheel.)

## GLOVE COMPARTMENT LOCK

To lock the glove compartment, give the key a quarter turn counterclockwise. To open the compartment, turn the catch button clockwise.



5 2007

### IGNITION SWITCH AND GEAR LEVER LOCK

#### Manual transmission

The key has four positions:

- L. In this position and with reverse gear engaged, the gear lever is locked and the key can be withdrawn.  
Parking light and hazard warning signal can be switched on.
- G. Garage position. All lights can be switched on.
- K. Drive position. All electrical systems including ignition are operational.
- S. Start position, with spring-loaded return to K.

**Note!** To ensure that the car isn't left unlocked, there will be a buzzer activated if the door is opened with the key left in the ignition lock.

#### Automatic transmission

The combined ignition switch and gear selector lever lock has four positions:

- L. Locked. With the key in this position and reverse gear

### Ignition switch and gear shift (selector) lever lock

engaged, the selector lever is locked and the key can be withdrawn.

- G. Garage. All lights can be switched on.
- K. Drive. All electric systems including ignition are operational.
- S. Start. This position has a spring-loaded return to K.  
The starter motor can only be operated with the selector lever at N or P.

**Note!** To ensure that the car isn't left unlocked, there will be a buzzer activated if the door is opened with the key left in the ignition lock.

# CONTROLS AND INSTRUMENTS

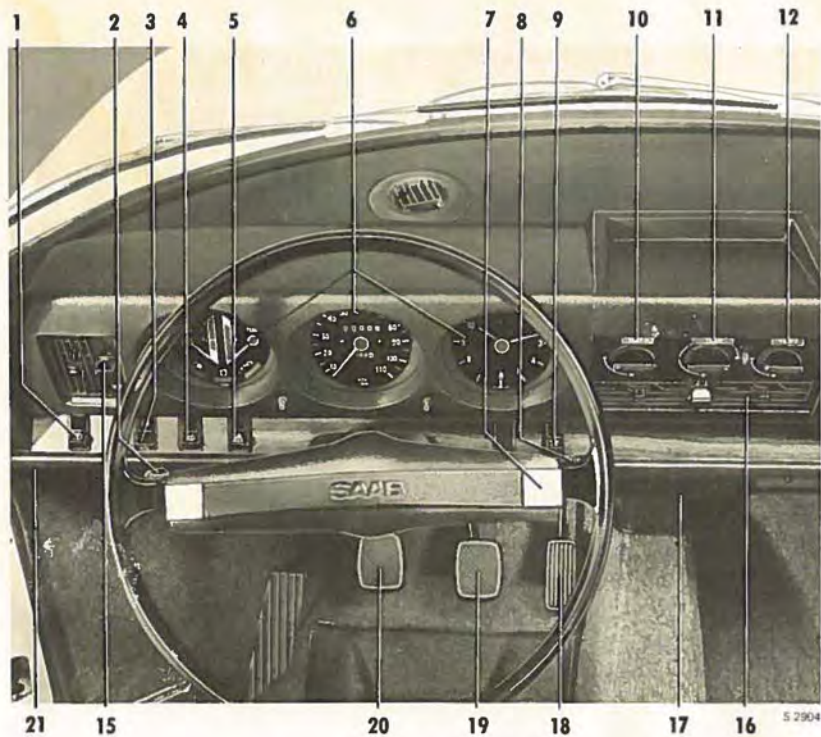

Controls and instruments



Manual transmission



Automatic transmission

### CONTROLS AND INSTRUMENTS

1. Headlight and parking light switch
  2. Combined direction indicator lever, headlight dimmer and headlight flasher switch.
  3. For cars with injection engines:  
Spare switch.  
For cars with carbureted engines:  
Choke with warning light.
  4. Switch for instrument and control lighting.
  5. Hazard warning signal switch.
  6. Instruments and indicator lights.
  7. Horn control.
  8. Windshield wiper and washer control
  9. Ventilator fan switch.
  10. Defroster control for windshield and front side windows.
  11. Temperature control.
  12. Ventilation control for front seat floor.
  13. Ventilation control for back seat floor.
  14. Defroster control for rear window.
  15. Fresh air vents, side.
  16. Fresh air vent, center.
  17. Ashtray with lighter.
  18. Accelerator pedal.
  19. Brake pedal.
  20. Clutch pedal (cars with manual transmission).
  21. Hood lock release handle.
  22. Gear (selector) lever; see pp. 25 and 26.
  23. Handbrake.
  25. Interior lighting switch; see p. 18.
  26. Ignition switch and gear (selector) lever lock; see p. 9.
- The functions of the instruments and the operation of those controls that need further explanation are described in the next few pages. Figures in the margin refer to the above list.

## CONTROLS AND INSTRUMENTS

1. Headlight and parking light switch.  
The tangent switch has three positions: Top pushed in – lights off, intermediate position – parking lights on independent of ignition key position, bottom pushed in – headlights on if ignition key is at G or K.

NOTE! The headlights are automatically extinguished when the ignition key is turned to L. The parking lights can however be lit if the switch is moved to the intermediate position.

2. Combined direction indicator lever and headlight dimmer and flasher switch.  
To shift between high and dimmed beam, pull the lever towards the steering wheel. The same action flashes a high-beam signal when the headlights are switched off. To operate the direction indicator lights, move the lever in the direction in which the steering wheel is turned.
4. Switch for instrument and control lighting.  
The tangent switch has three positions: top pushed in – off; intermediate – subdued light; bottom pushed in – full illumination.



S 2905

### Combined direction indicator lever and headlight dimmer and flasher switch

1. Left direction indicator
2. Right direction indicator
3. Headlight dimmer and flasher switch

5.  Hazard warning signal switch.  
All direction indicator lights flash together when the button is pushed in. The hazard warning signal must only be used when the car is immobilized by accident, breakdown, etc. in a position where it is liable to endanger or obstruct traffic.



**Instruments and indicator lights**

### 6. Instruments and indicator lights.

#### A. Combination instrument comprising:

- TEMP Temperature gauge for engine coolant.
- TANK Fuel gauge.



Brake indicator and warning light. This light glows red when the handbrake is on or to indicate excessive brake pedal stroke. If it lights up because the pedal goes too far down, this may be due to leakage from one of the two brake line circuits (wear on brake pads is indicated by increased pedal resistance). The reason should be investigated immediately and any necessary repairs made by an authorized Saab dealer.



Direction indicator repeater light. Flashes green in time with the direction indicators.



High beam warning light. Shows a blue light when the headlights are on high beam.



Charge indicator light. If this light glows yellow, the alternator is not charging.



Fuel reserve warning light. Shows a steady red glow when there are less than 2 US gallons (8 liters) left in the tank.



Oil pressure warning light. Glows red to indicate dangerously low oil pressure or oil level. When starting, never move off until this light has gone out. If it lights up while you are driving, switch off the engine at once and investigate the cause.

#### B. Speedometer, odometer and trip meter.

The zeroing button for the trip meter is located to the left of the speedometer.

#### C. Clock. The setting button is located to the left of the clock dial.

## CONTROLS AND INSTRUMENTS

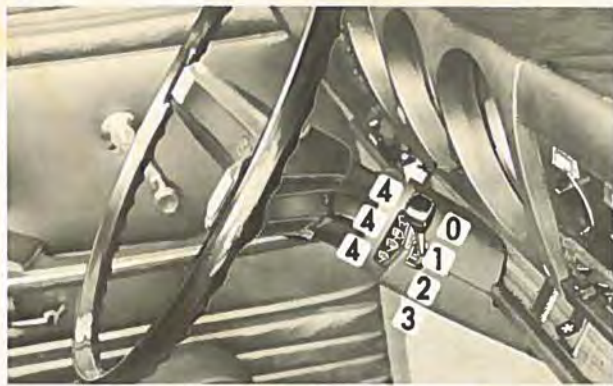

S 3073

### Windshield wiper and washer control lever

- 0. Neutral position
- 1. Windshield wipers, half speed
- 2. Windshield wipers, full speed
- 3. Windshield wipers, full speed + washer
- 4. Washer (works in positions 0, 1, 2)

- 8. Windshield wiper and washer control — see illustration
- 9. Ventilator fan switch. Push half-way down to run the fan at half speed, all the way down for full speed.

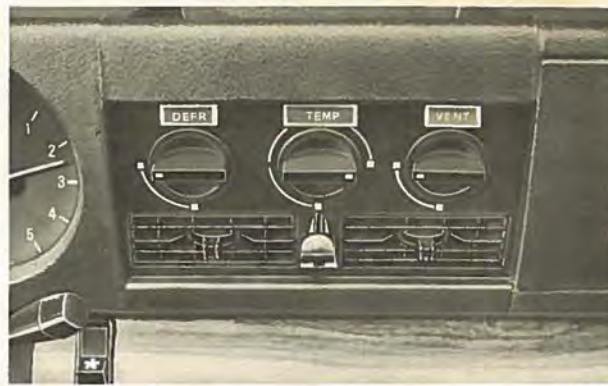

S 2786

### Front seat heating and ventilation controls

- 10—
- 14. Heater and ventilation controls. Air circulation in the passenger compartment is provided by the intake of fresh air — heated or cold — through the heating and ventilation system and exhaust through openings in the rear corner posts. These openings communicate with outlets in the body sides (see illustration). Controls 10 and 12 on the instrument panel, DEFRO and VENT (see illustration p.10) regulate the admission of heated or cold air. The temperature of the incoming air is adjusted with control 11, TEMP, which acts on the thermostat-regulated water valve. The thermostat compensates

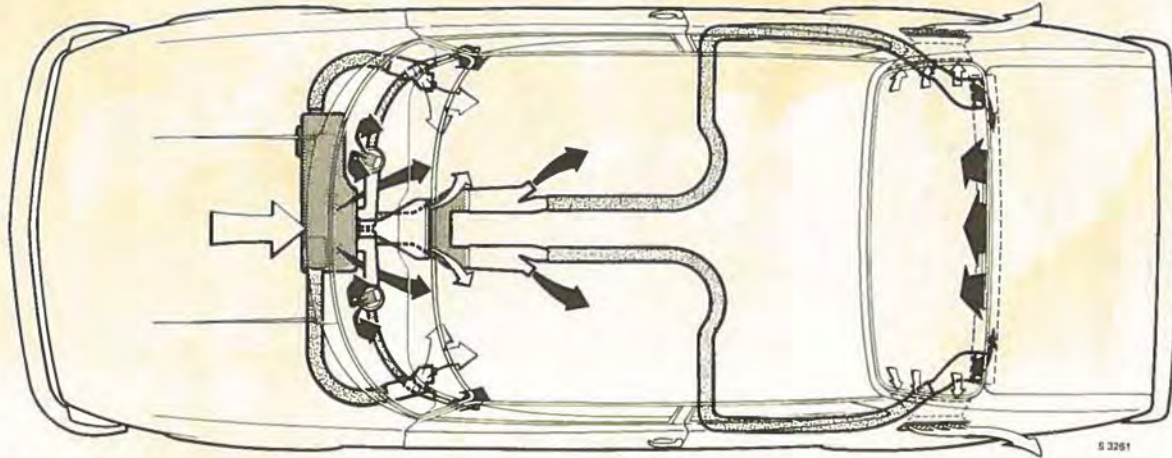

**Diagram of heating and ventilation system**

for variations in the air velocity and water temperature to keep the incoming air at a constant temperature corresponding to the control setting. Maximum heating effect is obtained when the knob is turned all the way to the red stop at the right. The heater is off when the knob is turned to the white stop at the left.

The knob marked DEFRO regulates the flow of air to the windshield and front side windows. Full flow is obtained with the knob horizontal, while turning to the vertical position shuts off the flow.

The knob marked VENT regulates the flow of air to

The knob marked VENT regulates the flow of air to the front seat floor space. Here too, the horizontal and vertical positions correspond to wide open and shut respectively.

The air supply to the rear window and rear floor space is regulated by the controls located to the right of the handbrake between the front seats. These controls can also be operated by the back-seat passengers.



## CONTROLS AND INSTRUMENTS

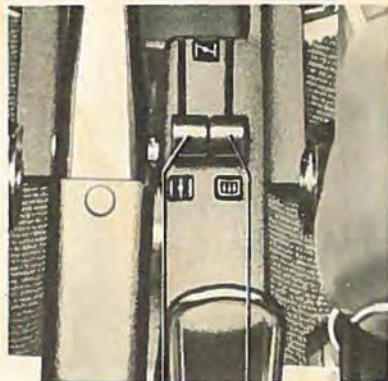

13 14

### Back seat heating and ventilation controls

- 13. Ventilation control, back seat floor
- 14. Rear window defroster controls

The left-hand control lever regulates the air inflow to the rear floor space, while the right-hand one operates the rear window defroster. In both cases the action is right forward to shut off, right back for full flow.

The car is equipped with a ventilator fan which boosts the inflow of air, especially at low road speeds. The fan runs at half speed when the switch is pushed half-way down and at full speed with the switch all the way down.

Maximum windshield defrosting effect is obtained

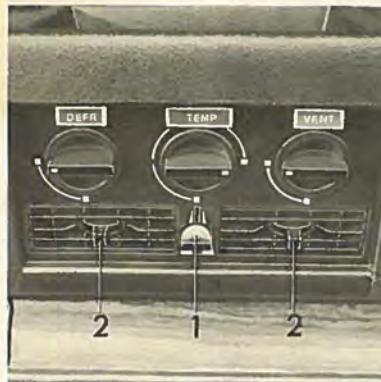

S 2787

### Fresh air vent, center

- 1. On-off control
- 2. Flow direction control

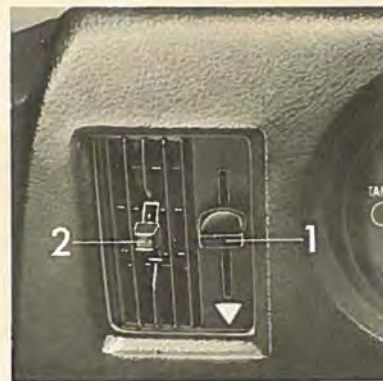

S 2907

### Fresh air vent, side

- 1. On-off control
- 2. Flow direction control

with only the DEFER control knob on the panel set to open and the fan running at full speed. The air flow can similarly be concentrated to the rear window or the front and rear floor space by manipulation of the appropriate controls.

The vents located at the outer ends and in the center of the instrument panel admit unheated air only. They are regulated by control lever 1 (up to close, down to open), and the direction of the air flow can be adjusted by moving lever 2 in the corresponding direction (see illustrations). The air inflow through the outboard vents increases when the fan is switched on.



5 2908

**Hood lock release handle**



5 2928

**Hood safety catch**

21. Hood lock release handle.  
The handle is located under the instrument panel just by the wall of the left wheel housing.  
To open the hood, proceed as follows:
- Pull the handle under the instrument panel. The hood will then open to the half-locked position, retained by a safety catch at the leading edge.
  - Press the leading edge of the hood down slightly and push back the safety catch. The leading edge will then spring up, and the whole hood can be tilted forward.

23. Handbrake.  
The handbrake acts on the front wheels.  
A warning light glows red when the handbrake is on and when the ignition key is in position K.

## INTERIOR FITTINGS AND SEATS

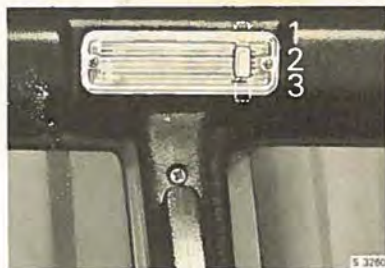

### Interior lighting

1. Light switches on when either door is opened
2. Light switched off
3. Light switched on

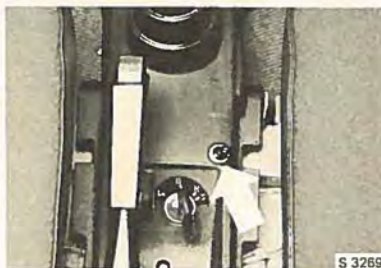

Switch on gear lever console, cars with manual transmission



Switch on selector console, cars with automatic transmission

## INTERIOR LIGHTING

There are three interior lights: one on the left doorpost, one at the rear view mirror and one beside the ignition

switch, all controlled by the switch on the doorpost light, which has three positions (see illustration above left). The



5 3047

### Interior mirror

1. Anti-dazzle button

lights can also be turned on by a switch on the gear lever console (see illustration above right). This latter switch is wired like the door contacts and only works when the doorpost light switch is in the top position (1).

Make sure when parking the car that the interior lights are turned off.

### ASHTRAYS

The ashtray with the built-in cigarette lighter is located in the center of the panel at its bottom edge.

Current is supplied to the lighter only when the ashtray is pulled all the way out.

There are also ashtrays in the back seat armrests.

### REAR-VIEW MIRRORS

The interior rear-view mirror can be deflected to avoid dazzle by operation of the control button underneath it. The exterior mirrors are anti-dazzle coated.

## INTERIOR FITTINGS AND SEATS

### FRONT SEATS

The backrest and cushion of the driver's seat have thermostat-controlled electric heating elements that warm up automatically when the ignition is switched on. The thermostat ensures that the heaters are switched on only when the seat is cold.

Both front seats are adjustable for legroom, and the driver's seat can also be adjusted for height. The backrest angle is continuously adjustable in two separate ranges, upright and reclining.

#### Legroom adjustment

Release catch 1 (right-hand illustration on p. 21) and slide the seat to the desired position.

#### Dropping the backrest forward

Push down catch 4 (see illustration) and drop the backrest forward.

#### Vertical adjustment

The cushion of the driver's seat can be raised and lowered and also tilted to the front or rear. As the illustration shows, there are four possible positions.

Adjustments are made with the handle at the forward edge of the seat. Release the catch by pushing on the handle and moving it to the intermediate position. The seat can now be adjusted as follows:

- A. Raised seat — move the handle back without pressing down on the seat.
- B. Lowered seat — move the handle forward, pressing down on the seat.
- C. Seat tilted back — move the handle back, pressing down on the seat.
- D. Seat tilted forward — move the handle forward without pressing down on the seat.

#### Backrest angle adjustment

The backrest can be set to three different positions — upright, reclining and fully dropped. In the upright and reclining positions the angle can be steplessly adjusted with knob 3. To drop the backrest to reclining, lever 4 must be pushed down to release the catch. The same applies when the seat is to be returned to the upright position. From reclining, the backrest can be dropped all the way to rest against the back seat if lever 4 is pushed down. (For bedding down, see under "Back seat — Trunk".)

#### To take out driver's seat

1. Disconnect the electric heater wiring (under the seat).
2. Release the seat by moving handle 2 to the intermediate position.
3. Push back the catches 5 and drop the backrest for-

## INTERIOR FITTINGS AND SEATS

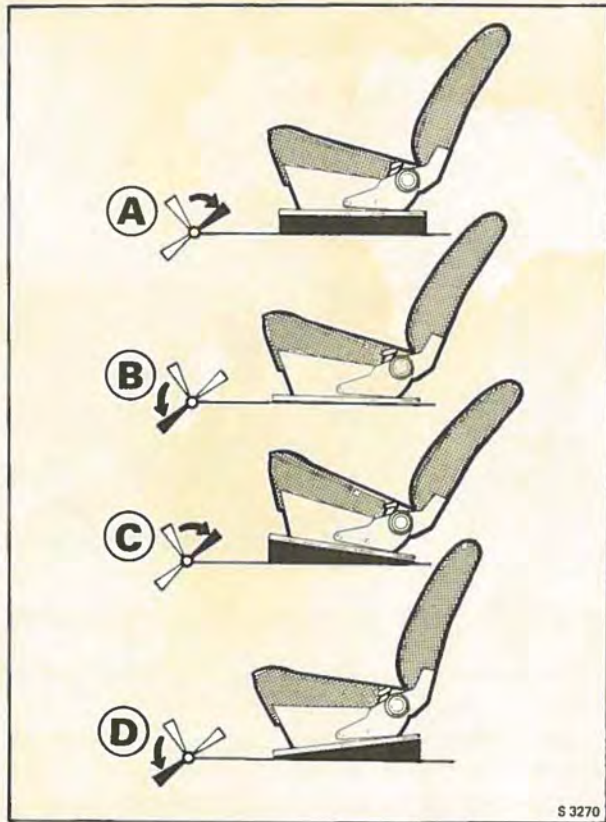

**Vertical adjustment of driver's seat**

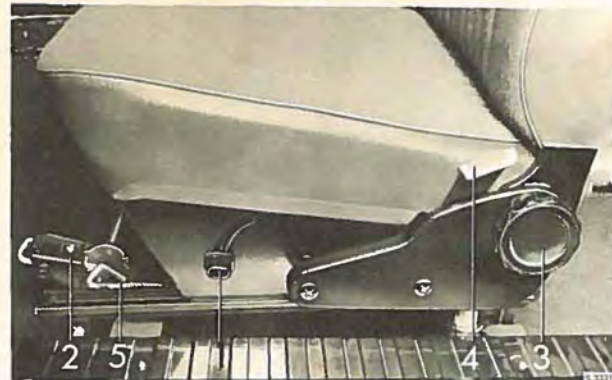

### **Front seat**

1. Legroom adjustment catch
2. Vertical adjustment handle (driver's seat only)
3. Backrest angle adjusting knob
4. Backrest release (to drop backrest forward or back)
5. Catch

ward. Lift the seat by the forward edge, tip it backward and free it from its rear attachments. Install in the reverse order.

### **To take out the front passenger seat**

Undo the retaining screws from the seat rails, using the special wrench provided in the tool kit. The seat can then be lifted out.

## INTERIOR FITTINGS AND SEATS



Passenger compartment

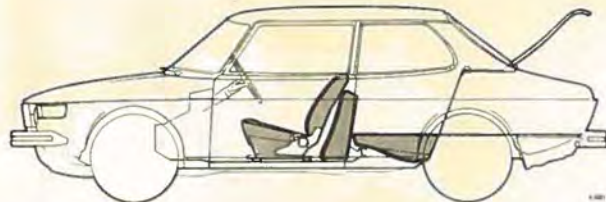

Cargo space



S 2791

Catch, backrest



S 2829

Seat cushion catch, 4-door model



S 2792

Seat cushion catch, 2-door model

### BACK SEAT – TRUNK

The back seat can be converted if required into additional cargo space on the station wagon principle by rearrangement of the cushions as follows:

Release the backrest catch (see illustration). Then release the seat cushion catch (at the front of the cushion – see illustration), lift the front edge of the cushion (2-door model) and tip the cushion forward to stand it on edge behind the front seats. Pull the backrest forward and down.

It is also possible to bed down in the cargo space. If more legroom is needed for bedding, the following rearrangements can be made:

Slide the front seats as far forward as they will go and drop the backrests forward. Tip up the back seat cushion and undo the screws (two in 2-door cars, eight in 4-door) holding it. Place the cushion as a bolster between the front and back seats and drop the backrest forward.

## INTERIOR FITTINGS AND SEATS

### SAFETY BELTS

#### For driver and front-seat passenger

The belt locks on to the yoke between the front seats when the buckle is pressed against the yoke, and is released when the buckle cover is pulled up.

To shorten the straps, pull on the ends (lap strap dark, shoulder strap light).

To let out the straps, pull on them while holding down the strap retainer.

#### For back-seat passengers

To secure the belt, slide the two halves of the buckle together, to release it, pull up the buckle flap.

To shorten the belt, pull on the free end, and to let it out, hold the upper half of the buckle at right angles to its strap and pull it down.



S 1614

Shortening the lap strap



S 1615

Shortening the shoulder strap

1. Strap retainer
2. Buckle cover



S 1616

Belt hanger



S 2504

Safety belt, back seat

To perform its life-saving function, the belt must be adjusted to a close fit. Always check before starting out that the belt is not twisted, and make sure that it is not chafing on sharp corners and has not snagged.

The hooks for hanging up front-seat belts are located on the courtesy handles in 2-door cars. Back-seat belts are hung up on the upper anchoring points.

#### Warning

No alterations or additions should be made to this belt which might impair its efficiency.

The webbing must not be bleached or redyed.

The belt must be worn close to the body to give full



## DRIVING INSTRUCTIONS

protection. The belt is meant for one person only. The shoulder belt is not to be used without a lap belt. If in doubt on any matter concerning this belt or its use please consult the manufacturer.

### STARTING THE ENGINE

#### General

Do not run the starter for more than 20–25 seconds at a stretch; wait 20–30 seconds to let the battery recover before attempting to start again. Make sure that all other current-consuming equipment is switched off during the starting maneuver.

Do not race the engine or make it work too hard while it is still cold, and on no account do so while the oil pressure warning light is still lit. Avoid warming the engine by idling at a standstill; start driving as soon as the oil pressure warning light goes out to get the engine up to its proper working temperature as quickly as possible.

#### Carbureted engine

The carburetor is equipped with a manual choke to assist starting when the engine is cold. Pulling out the choke

button also adjusts the throttle to give the engine the higher idling speed it needs. Never pull out the choke when the engine is warm.

1. Apply the handbrake and put the gear lever in neutral (manual transmission) or select P or N (automatic transmission).

NOTE! Cars with automatic transmission can only be started when the selector lever is at N or P.

2. If the engine is cold, pull the choke button all the way out. Do not touch the accelerator pedal. If the engine is warm and the outdoor temperature is high, depress the accelerator pedal half-way.
3. Depress the clutch pedal (manual transmission).
4. Turn the ignition key to start (S), letting it spring back to drive (K) as soon as the engine fires.
5. Ease the choke button in gradually as the engine warms

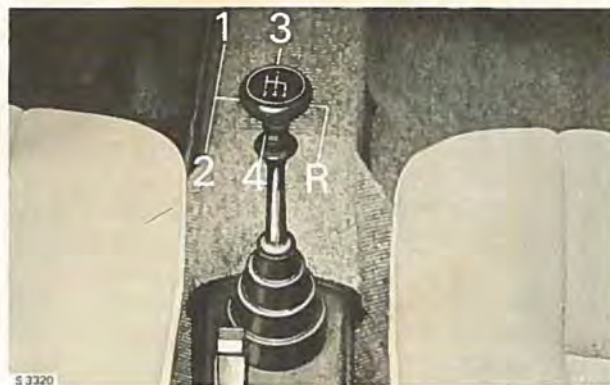

**Gear lever positions, manual transmission**

up. Do not drive any longer than absolutely necessary with the choke button out.

### **Injection engine**

The engine has an automatic choke. Start as follows:

1. Apply the handbrake and put the gear lever in neutral (manual transmission) or select P or N (automatic transmission).

NOTE! Cars with automatic transmission can only be started when the selector lever is at N or P.

2. Depress the clutch pedal (manual transmission).
3. Turn the ignition key to start (S), letting it spring back to drive (K) when the engine fires. Do not touch the accelerator pedal. However, if the engine is warm and the outdoor temperature is high, a slight depression of the accelerator pedal will assist starting.

### **MANUAL TRANSMISSION**

The gear positions are illustrated above. To engage reverse gear, the catch on the gear lever must first be pulled up. After shifting gears, release the clutch pedal smoothly and carefully. There are only two proper clutch positions for driving, either out (pedal fully depressed) or in (pedal released). It is a bad habit to drive with a slipping clutch or with the foot resting on the clutch pedal, as this causes heavy wear on the release bearing and clutch disc. When the car is standing still with the engine running, the gear lever should be in neutral and the clutch pedal released. In all shifts, move the lever gently but firmly and with a slight, barely perceptible pause in neutral.

## DRIVING INSTRUCTIONS

### AUTOMATIC TRANSMISSION

The following basic rules for operation of the automatic transmission should be kept in mind:

1. Always press on the footbrake or have the handbrake on when shifting the selector lever if the car is at a standstill with the engine idling. Otherwise the car will start to creep forward when a driving gear is selected, as the torque converter does not disengage the transmission completely.
2. The engine should be at idling speed if you shift the selector lever while the car is at a standstill. If you race the engine while shifting the lever, this is liable to cause abnormal wear on the transmission mechanism. For the same reason you should not shift to R or P while the car is in motion.

### GEAR SELECTOR LEVER

#### Positions

A scale beside the gear selector lever is marked with symbols indicating the different positions:

P = Park

R = Reverse

N = Neutral

D = Drive

2 = 2nd gear

1 = 1st gear

} Forward gears



5 2837

**Gear selector lever**

The lever can be shifted freely between N and D. The other positions are blocked by a catch that is released when the button in the center of the lever knob is depressed. The lever can however be shifted back to D or N from R, 2 or 1 without the knob being pressed.

#### Selecting gears

- D. The D (Drive) position is for normal forward driving. Whichever of the three forward gears best matches the speed and load on the engine is automatically engaged.

2. Position 2 gives automatic shift between first and second gears but top gear cannot be engaged. If the lever is moved from D to 2, this gives an immediate downshift for more engine braking power. Position 2 must not be selected at road speeds above 55 miles per hour (90 km/h).
1. Position 1 used to obtain maximum engine braking power on steep downgrades. Road speed must be reduced to below about 12 mph (20 km/h) before 1st gear is engaged. This position should also be used for uphill driving on very steep hills to avoid overheating the transmission oil. Second and top gears cannot be engaged when the lever is at 1.
- N. In position N (Neutral) no gear is engaged. The starter contact is operative in this position. The handbrake should be applied when the selector lever is in position N to prevent the car from moving if it is standing on a slope.
- R. Position R (Reverse) must not be selected unless the car is stationary.
- P. Position P (Park) is selected when the car is parked,

and the lever must be in this position before the ignition key can be turned to L (Locked) and withdrawn. The selector lever is then locked and the transmission is immobilized. The starter contact is operative in position P. Do not select position P when the car is in motion.

### **Moving off**

1. Shift the selector lever to the desired position (normally D for forward driving).
2. Release the brake and accelerate.

### **Kick-down**

To obtain maximum acceleration, e.g. for overtaking, it is possible to effect an instant downshift at speeds below 50–55 mph (80–85 km/h) by pushing the accelerator pedal hard down to the “kick-down” position. Upshift to the next higher gear is automatic as soon as the engine reaches maximum revs for the gear engaged or when the pedal is eased up.

## DRIVING INSTRUCTIONS

### BRAKES

The car is delivered with a thoroughly tested set of brake linings with very little tendency to fade, i.e. they can tolerate high temperatures without serious loss of effect. Always make sure when changing brake linings and pads that original Saab spare parts are fitted. See also "Brake system".

To avoid subjecting the brakes to excessively high temperatures, e.g. when driving downhill in mountainous country with descents of thousands of feet, you should drive in a low gear (manual transmission) or select "1" (automatic transmission) to utilize the braking power of the engine.

#### **Important**

It is good policy to try the brakes occasionally when driving to make sure that they are working properly, especially if they have been subjected to heavy splashing with water or if you are driving through snow or salty slush, as braking power may be temporarily reduced in conditions of this kind. The brake system is equipped with a power assist, but the added power from this is only available when the engine is running. It takes much harder pressure on the pedal to brake the car when the engine is switched off.

### TIRES

The Saab 99 is factory-equipped with tubeless radial tires (size 155—SR 15) which give the best road-holding characteristics in most conditions.

### STEERING CHARACTERISTICS

The Saab 99 has a built-in tendency to understeer, i.e. at a given position of the steering wheel the turning radius tends to increase with rising speed. The car is deliberately designed this way to improve its stability and reduce the risk of a back-wheel skid. One of the ways in which understeer has been achieved is the weight distribution. With driver about 60 % of the vehicle weight is on the front wheels and fully loaded about 50 %.

### BREAK IN

Every new car has a recommended break-in period during which the owner is advised to drive with restraint. Pistons, cylinder walls and bearings need to be in operation for some time to produce smooth and hard-wearing contact surfaces. Placing too much strain on a new engine interferes with this gradual bedding-down process, shortening the life of the car and especially the engine. For the first 2.000 miles (3.000 km) you should not drive at full throttle except for very brief periods.

### DRIVING ECONOMY

For maximum economy of both fuel and wear, the Saab 99 like any other car needs to be driven with care. Avoid violent acceleration and high engine speeds, especially in the low gears.

### DRIVING ON SLIPPERY ROADS

When the roads are icy it is more important than ever to keep your car in good trim – especially the brakes and tires. Studded tires give the best grip on icy roads, **provided they are fitted on all four wheels**. Never use a mixed set of tires, but always have the same kind on all wheels.

With the onset of wintry and icy conditions, it is a good idea to find a quiet space with no traffic and plenty of room, and practise braking and cornering to familiarise yourself with the behavior of the car on a slippery surface.

If the car goes into a skid, ease up on the throttle or release the accelerator carefully altogether; above all, do not touch the brakes. To correct a back-wheel skid, steer in the direction the rear end is sliding. To correct a front-wheel skid, steer gently into the line you wish to take.

## DRIVING INSTRUCTIONS

### A FEW USEFUL HINTS

1. Make sure that the ignition is switched off when the engine is not running. Otherwise the ignition coil and breaker contacts may be damaged.
2. If your car has a carburetor, make sure that the air cleaner intake is set properly to "Summer" or "Winter" according to the time of year.
3. Keep the battery well charged up at all times. You may have trouble starting if the charge is low. With regard to the battery connections, see under "Alternator" and "Battery".
4. In wintertime you should take steps to prevent the door and trunk locks from freezing stuck. Suitable de-icing preparations are sold by most service stations. If a lock cylinder should freeze up, be careful not to bend the key by trying to force it. Melt the ice by warming the lock or the key.
5. All tires used on the car should at all times be of similar and equivalent construction. Studded or unstudded winter tires should not be installed unless they are installed on all four wheels.
6. Anti-skid devices.  
Snap-on links must not be used, as they will damage the disc brakes. Use ordinary snow chains instead; these can be fitted to both the front and back wheels. But be careful when driving with snow chains, as they may foul the bodywork at extreme spring compression and extreme steering lock.
7. Keep the brakes in good condition at all times. Check

regularly to make sure that

- a) the brake pedal does not continue to go down under constant pressure;
- b) braking effect is satisfactory;
- c) the car does not pull to one side when braked;
- d) the brake warning light works.
- e) the handbrake is working properly.

See also under "Brake system".

If you have any trouble with the brakes, have them seen to by an authorized Saab dealer.

- 8. Avoid driving with the trunk lid open, as exhaust gases may then be sucked back into the car. If for any reason you have to drive with the back end open, you should take the following precautions:
  - a) Keep all windows closed.
  - b) Open the fresh air vents, set the defroster controls to wide open, and run the ventilator fan at full speed.



## MAINTENANCE



Oil filler cap, engine



Oil dipstick, engine

### FUEL

Recommended grade of fuel:

Injection engines — Regular fuel (minimum 91 octan)

Carburetor engines — Premium fuel (minimum 97 octan)

### ENGINE OIL

Oil volume: 4 US quarts (3.5 liters) including oil filter.

Quality: According to Service SD in the API system or to Ford specification ESE—M2C—101B.

Viscosity: SAE 10 W 30 or SAE 10 W 40.

In conditions of extreme cold with the temperature permanently below  $-4^{\circ}\text{F}$  ( $-20^{\circ}\text{C}$ ), oil of viscosity class SAE 5 W 20 should be used.

**WARNING!** This grade of oil must not be used at temperatures above  $+32^{\circ}\text{F}$  ( $0^{\circ}\text{C}$ ).

Check the engine oil level at regular intervals, after the en-

gine has been stopped for at least one minute. Do not let the level fall below the lower mark on the dipstick, but do not fill beyond the upper mark; this will cause needlessly high oil consumption. The distance between the upper and lower marks corresponds to a volume of approx. 1 US quart (1 liter). Top up with oil of recommended grade as necessary.

Engine oil should be changed for the first time after 1.000 miles (1.600 km) next time at 6.000 miles (10.000 km) and thereafter at 6.000-mile (10.000 km) intervals. Change the oil filter insert every 6.000 miles (10.000 km).

**NOTE!** Do not confuse the engine and transmission drain plugs (see illustration on pp. 35 and 37).

## TRANSMISSION OIL

### Manual transmission

SAE 75 or 80 EP oil to specification API-GL-5.  
In cold climate SAE 75 must be used.

### Automatic transmission

Automatic transmission oil according to Ford specification M2C.33F.

Automatic transmission oil Type A, Suffix A and Dextron may also be used for topping up.

Final drive: SAE 75 or 80 EP oil to specification API-GL-5.

## COOLING SYSTEM

Your car is delivered from the factory ready-filled with anti-freeze coolant. Check regularly that the coolant is up to the prescribed level. If the radiator needs topping off, make sure that the coolant you add is absolutely clean. Never add large amounts of cold water when the engine is warm, as this may crack the cylinder block. In winter, use anti-freeze coolant mixtures (see directions on p. 47.)

**Never screen off the radiator!**

## BRAKES

As a matter of safety, always follow the instructions given in the Service Book for checking the brake system and the

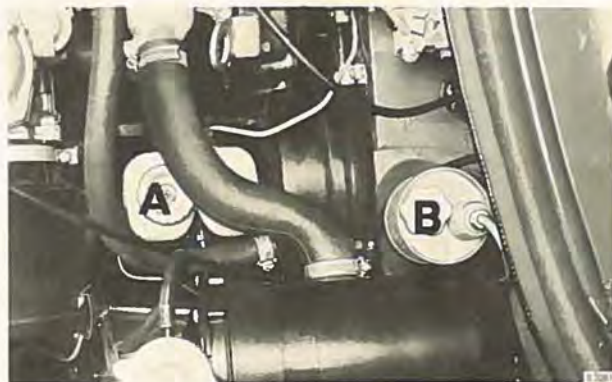

**A) Brake fluid container**

**B) Clutch fluid container (manual transmission)**

liquid levels in the brake and clutch system containers. Note that brake fluid must be changed after 24,000 miles (40,000 km) or at least every two years. See also p. 53.  
**NOTE!** Check brake linings regularly for signs of wear.

## BATTERY

You should check the electrolyte level in the battery at least once a month in winter and every two weeks in summer. Top up with distilled water as necessary. Clean the battery pole terminals regularly and grease them with vaseline.

## MAINTENANCE

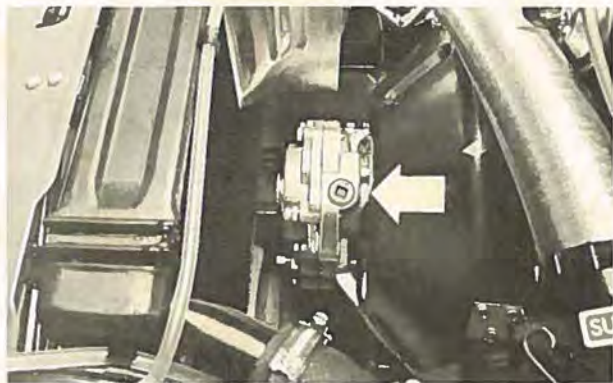

S 3108

Filler plug, manual transmission, version 1

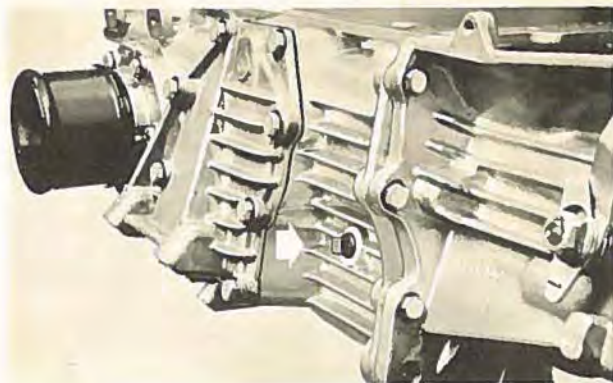

S 2020

Oil level plug, manual transmission, version 1

## TIRE PRESSURES

Check the tire pressures regularly.

Overinflated tires give a bumpy ride and wear excessively at the center of the tread. Underinflated tires suffer heavy wear on the shoulders and may cause the car to lurch when cornering. A correctly inflated tire grips the road over the full width of the tread and wears evenly.

### Tire pressures

Lightly loaded, front and rear . . . . . 27 psi (1.9 bar)

Fully loaded, front and rear . . . . . 30 psi (2.1 bar)

The pressures refer to cold tires.

## WINDSHIELD WASHER

To fill the container, turn the cap with pump 90° counter-clockwise and lift off. If the washer nozzle is blocked or sprays in the wrong direction, it can be cleaned with a pin or similar. The nozzle openings are in swiveling balls and can be adjusted to the desired position.

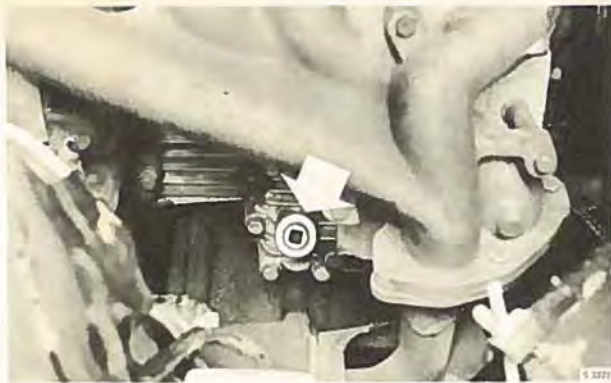

**Filler plug and oil level plug, manual transmission, version 2**

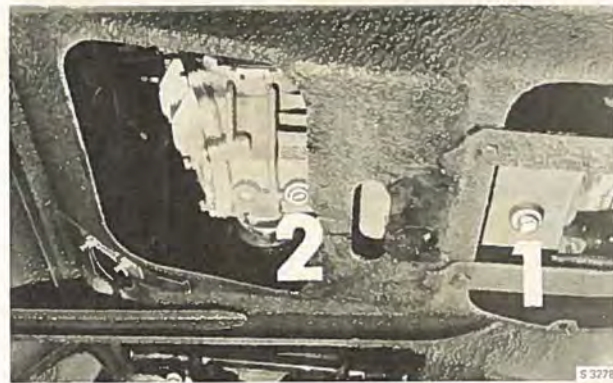

**Drain plugs, manual transmission**

- 1. Engine
- 2. Transmission

**LUBRICATING INSTRUCTIONS FOR CARS WITH MANUAL TRANSMISSION**

Lubrication should be carried out according to the lubrication chart on p. 38.

Engine oil and oil filter cartridge should be changed every 6,000 miles (10,000 km) or twice a year. Check the oil level in the transmission every 6,000 miles (10,000 km) by unscrewing the level gauge plug. Top up as necessary. The transmission oil should be changed and the magnetic drain plug cleaned after the first 1,000 miles (1,600 km),

and at intervals of 12,000 miles (20,000 km) thereafter. Drive the car for 15–20 minutes before draining the old oil. Refill with about 3 US quarts (3 liters) of SAE 75 or 80 EP oil to specification API–GL–5. In cold climate SAE 75 must be used. A special wrench is needed to unscrew the transmission oil drain plug; this is to avoid any possibility of confusion between the engine and transmission drain plugs.

## MAINTENANCE



S 2834

Location of dipstick, automatic transmission

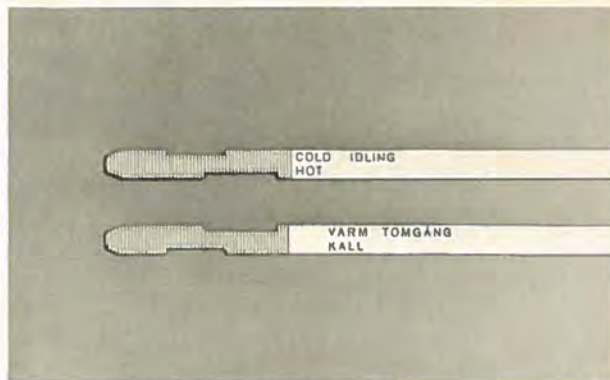

S 2578

Dipstick, automatic transmission

### LUBRICATING INSTRUCTIONS FOR CARS WITH AUTOMATIC TRANSMISSION

Lubrication should be carried out according to the lubrication chart on p. 38.

Engine oil and oil filter cartridge should be changed every 6,000 miles (10,000 km) or twice a year.

The oil in the automatic transmission does not need changing, but the level must be checked every 6,000 miles

(10,000 km). The filler tube with graduated dipstick is located immediately behind the radiator (see illustration above). The dipstick has different graduations for hot and cold oil levels. When the oil level is measured the car should be standing on a level surface with the selector at P and the engine idling. The oil level should then be somewhere between the top and bottom of the appropriate



**Oil level plug, final drive, automatic transmission**

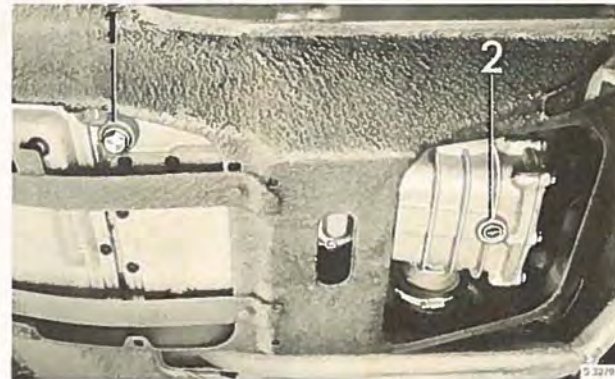

**Drain plugs, automatic transmission**

1. Engine
2. Final drive

cutout on the dipstick (see illustration).

Use a nylon rag, lint-free paper or chamois leather to wipe off the dipstick — do not use rags that may leave fluff on the dipstick.

If the transmission needs topping up, use only special automatic transmission oil (see recommendations on p.

33). The most scrupulous cleanliness must be observed during filling.

The oil in the final drive must be checked every 6,000 miles (10,000 km) and changed every 12,000 miles (20,000 km). Use SAE 75 or 80 EP oil to specification API-GL-5.

## MAINTENANCE

Lubrication every 6,000 miles (10,000 km) or at least twice a year

Ref.	Lubrication point	Qty.	Lubricant	Direction
1	Brake system	1	Brake fluid, grade SAE J 1703a or SAE 70 R3	Brake fluid to be changed every 24,000 miles (40,000 km) or at least every 2 years.
2	Hydraulic clutch	1	Brake fluid, grade as above	
3	Engine	1	See recommendations on p. 32	Change oil and oil filter cartridge NOTE! Use only Saab original filter cartridge.
4	Manual transmission		See recommendations on p. 35	Check every 6,000 miles (10,000 km), change every 12,000 miles (20,000 km)
	Automatic transmission			Check every 6,000 miles (10,000 km)
	Final drive, automatic transmission		See recommendations on p. 37	Check every 6,000 miles (10,000 km), change every 12,000 miles (20,000 km)
5	Carburetor (oil damper)	1	As for engine	Check every 6,000 miles (10,000 km) at time of service inspection
6	Distributor, breaker cam	1	Bosch Ft 1 v 4	Grease cam sparingly
	Distributor, lubr. felt under breaker plate	1	SAE 40 oil	Oil can through hole in breaker plate
7	Throttle control, wire bearing	1	SAE 40 oil	Oil can
8	Hood lock mechanism	1	SAE 40 oil	Oil can
9	Door hinges and door stops	4+4 (8+8)	SAE 40 oil	Oil can

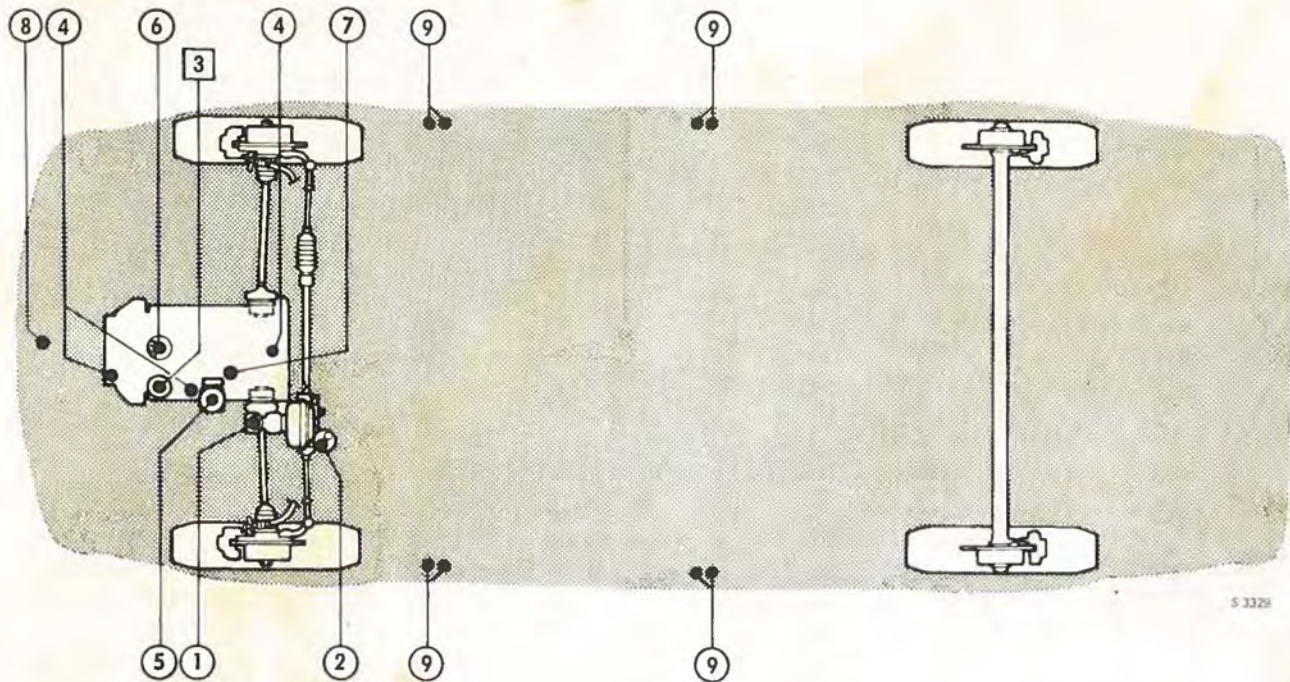

### Lubrication chart

Numbers refer to lubrication table.



## DESCRIPTION AND CARE

### ENGINE

#### General

The Saab 99 has a four-in-line liquid-cooled engine with overhead camshaft.

The cylinder block is canted 45° to the right and the cylinder head is of cross-flow type, i.e. with inlet ducts on one side and exhaust ducts on the other. The crankshaft is journaled in five main bearings. The engine has a separate idler shaft that drives the oil pump, water pump and distributor through cog gears. In the carbureted version the fuel pump is also driven by a cam on the idler shaft. The engine has fully enclosed crankcase ventilation, i.e. air is admitted via the air cleaner and conducted to the crankcase. Exhaust air from the crankcase leaves from the valve cover via a hose leading direct to the inlet manifold.

A valve located between the valve cover and the inlet manifold regulates the flow of air through the crankcase. The engine has the clutch mounted at the front end and the transmission underneath, all in one integral assembly called the power plant.

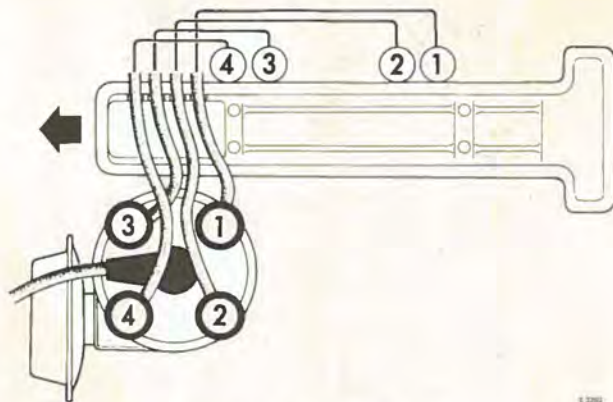

Position of ignition cables

#### Spark plugs

The spark plugs have been carefully tested; to get maximum power out of the engine, you must use one of the recommended types of plug (see p. 75). Any necessary adjustment should be made to the side electrode – if you try to bend the central electrode, the porcelain may crack. NOTE! When removing spark plugs, be very careful to see that no dirt falls into the cylinders.

#### Distributor

The distributor is located on the front of the engine block. Its rotor arm turns counterclockwise, driven by a pinion

## DESCRIPTION AND CARE

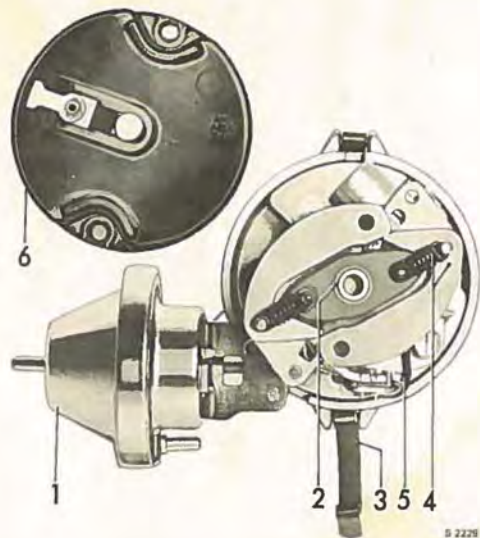

### Distributor, carbureted engine

- |                        |                      |
|------------------------|----------------------|
| 1. Vacuum control unit | 4. Weight spring set |
| 2. Distributor shaft   | 5. Condenser cable   |
| 3. Spring clip         | 6. Rotor             |

gear from the idler shaft. Ignition advance is accomplished by both centrifugal and vacuum advance. The order of firing is 1-3-4-2; with cylinder No. 1 farthest to the rear of the car.

### Ignition timing

Correct timing of the ignition is essential if full engine

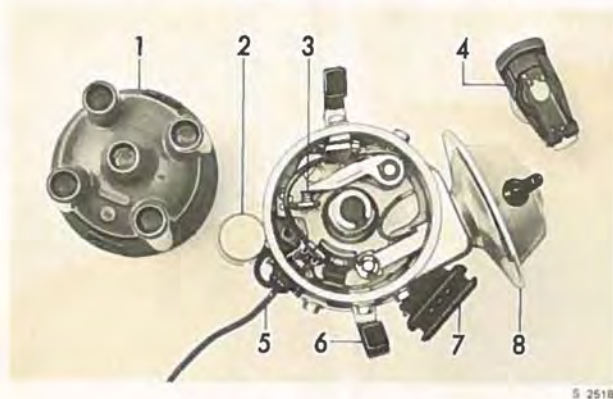

### Distributor, injection engine

- |                     |                                    |
|---------------------|------------------------------------|
| 1. Cover            | 5. Low-voltage connection          |
| 2. Condenser        | 6. Spring clip                     |
| 3. Breaker contacts | 7. Connection for trigger contacts |
| 4. Rotor            | 8. Vacuum control unit             |

power and fuel economy are to be obtained. Ignition timing is best checked with a stroboscope, which is a job for an authorized Saab dealer. Note that any adjustment of the contact gap will also affect the ignition timing.

Any adjustment of the timing will affect the exhaust emission and must only be carried out by an authorized Saab dealer as special test equipment is necessary.

## DESCRIPTION AND CARE

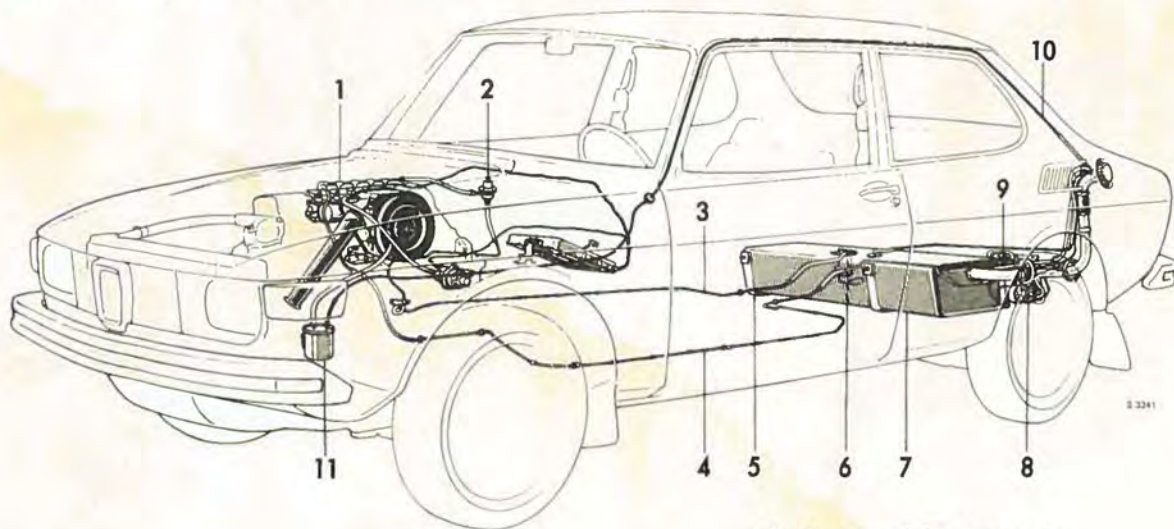

### Fuel system, injection engine

- |                           |   |
|---------------------------|---|
| 1. Injection valves       | 7. Drain plug (accessible from beneath the car) |
| 2. Pressure regulator     | 8. Fuel pump                                    |
| 3. Return fuel line       | 9. Fuel filter                                  |
| 4. Pressure fuel line     | 10. Vapor hose                                  |
| 5. Fuel tank              | 11. Charcoal canister                           |
| 6. Fuel level transmitter |   |

### FUEL SYSTEM, INJECTION ENGINE

#### General

The fuel system consists of tank, fuel lines, injection system, air cleaner and an evaporation loss control unit. The tank is located under the body between the rear wheels,

and the electric fuel level transmitter is mounted on top of the tank.

The evaporation loss control unit includes a charcoal canister which is placed in the engine compartment. It absorbs the vapor from the tank when the engine is not running.

The charcoal is purged when the engine is running. This is achieved by fresh air which is sucked through to the air cleaner.

The fuel filter and the canister filter should be renewed at intervals according to the directions given in the Service Book.

The car is equipped with a Bosch electronic fuel injection system. An electric fuel pump and a pressure regulator deliver fuel at constant pressure. The injection valves supply the four cylinders with an adjusted quantity of fuel. The fuel is injected into the inlet manifold just in front of the inlet valves and the fuel feed depends on how long the injection valves are open. This is controlled by an electronic unit and varies according to the load, speed and temperature of the engine.

Inspection and adjustment of the electronic fuel injection system require the use of special instruments and must be carried out by an authorized Saab dealer.

The fuel pump, together with a separate fuel filter, is located behind the fuel tank. The filter is accessible through a hatch in the trunk and should be replaced periodically (see Service Book).

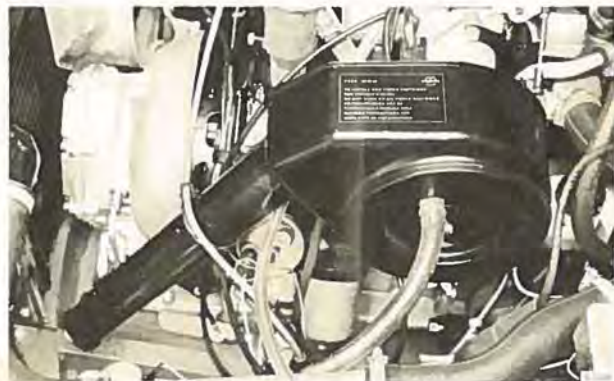

**Air cleaner, injection engine**

### **Air cleaner**

The air cleaner is located on the left-hand side of the engine. It serves to remove dirt from the engine intake air and to muffle intake noise. The replaceable filter insert should be changed every 18,000 miles (30,000 km) or every two years, whichever is the earlier. If you drive on dusty roads, you should change the filter insert more often. The insert is made of a special kind of paper and must not be washed or wetted, but can be cleaned by gently blowing with compressed air. The air cleaner housing and cover should be wiped off occasionally.

## DESCRIPTION AND CARE

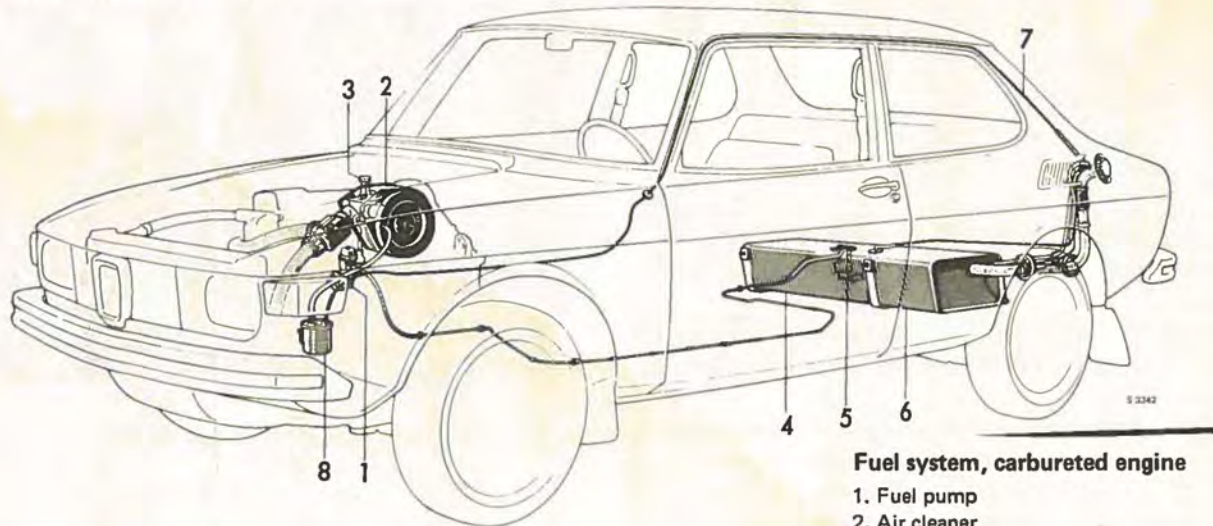

### Fuel system, carbureted engine

1. Fuel pump
2. Air cleaner
3. Carburetor
4. Fuel tank
5. Fuel level transmitter
6. Drain plug (accessible from beneath the car)
7. Vapor hose
8. Charcoal canister

### FUEL SYSTEM, CARBURETED ENGINE

#### General

The fuel system consists of tank, fuel lines, pump, carburetor and an evaporation loss control unit. The tank is located under the body between the rear wheels, and the electric fuel level transmitter is mounted on top of the tank.

The evaporation loss control unit includes a charcoal canister which is placed in the engine compartment. It absorbs the vapor from the tank when the engine is not running. The charcoal is purged when the engine is running. This is achieved by fresh air which is sucked through to the air cleaner.



S 2341

### Fuel pump, carbureted engine

1. Cover with gasket    2. Filter    3. Valve housing

The fuel filter and the canister filter should be renewed at intervals according to the directions given in the Service Book.

### Fuel pump

The fuel pump is a diaphragm type and is driven by a cam on the idler shaft. It is located on the left-hand side of the engine and is provided with an outside lever for manual priming of the carburetor.

The fuel pump has a filter that can be taken out for cleaning when the cover is removed. The filter should be cleaned according to the directions in the Service Book or if dirt in the fuel is suspected. When reassembling, make sure that gasket between the cover and filter is correctly positioned.



S 2377

### Air cleaner, carbureted engine

#### Air cleaner

The air cleaner is mounted on the carburetor on the left-hand side of the engine. It serves to remove dirt from the engine intake air and to muffle intake noise. The replaceable filter insert should be changed every 18,000 miles (30,000 km) or every two years, whichever is shorter. If you drive on dusty roads, change the filter insert more often. The insert is made of a special kind of paper and must not be washed but may be taken out and tapped gently to remove surface dirt. The air cleaner housing and cover should be wiped off occasionally. In cars with carburetor engines the air cleaner has a valve with two settings. In the "Summer" setting, air is drawn in direct through the intake pipe; in the "Winter" setting, the air enters

## DESCRIPTION AND CARE

through the casing surrounding the exhaust manifold, where it is preheated, and then goes to the air cleaner through a hose. The "Winter" setting should be used when the outdoor temperature consistently remains below  $+40^{\circ}\text{F}$  ( $+5^{\circ}\text{C}$ ).

### Carburetor

The carburetor engine is fitted with a Zenith-Stromberg horizontal carburetor with the type designation 175 CD-2 SE. This carburetor has only one jet, the cross-section area of fuel flow being varied by a movable tapered needle. The position of the needle is determined by the negative pressurization of the carburetor housing, which actuates a piston in which the needle is mounted. The carburetor is equipped with a cold start device to aid starting of a cold engine.

It is essential that any adjustment to the carburetor should be made according to the manufacturers recommendations. Faulty carburetor adjustment can cause abnormally high fuel consumption and rapid engine wear. The expert motorist may tune the idling speed up or down by means of the throttle screw, but any other adjustments should be made by an authorized Saab dealer.

Any adjustment of the engine idling will affect the exhaust emission and must only be carried out by an authorized Saab dealer as special test equipment is necessary.

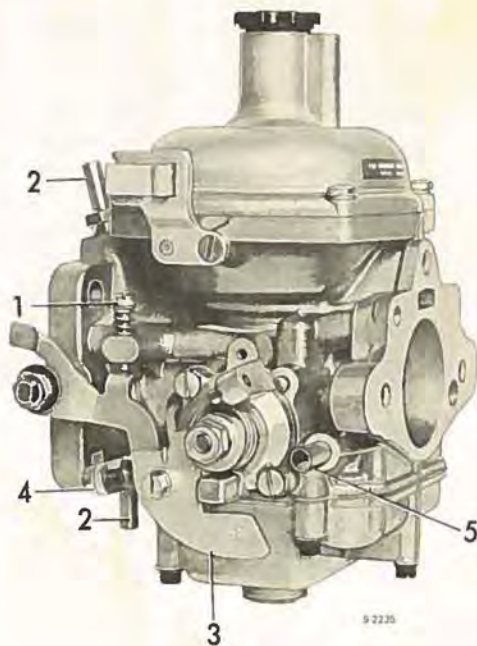

### Carburetor

1. Throttle screw
2. Vacuum nipple
3. Fast idling cam
4. Fast idling screw
5. Fuel inlet

## COOLING SYSTEM

### General

The cooling system is of pressurized type with a cross-flow radiator and expansion tank.

Until the engine has reached its proper operating temperature, the radiator inlet is closed by a thermostat and the coolant circulates through the engine and heater until it reaches a temperature of 185°F (85°C), at which point the thermostat opens.

### Filling or changing coolant

Check regularly to make sure that the coolant is up to the correct level. If the radiator needs topping up, use only absolutely clean liquid.

When adding coolant in large quantities or refilling the system with fresh coolant, proceed as follows:

1. Unscrew the pressure cap from the expansion tank.
2. Open the heater core bleeder nipple and set the heater control to maximum heat.
3. Fill the system with coolant. Start the engine and let it run at moderate speed until coolant overflows from the heater core bleeder nipple with no bubbles.

### CAUTION

Be very careful if for any reason the coolant should be boiling when you are about to remove the radiator cap. Loosen the cap gently and allow steam to escape before taking the cap off. Never add large quantities of coolant when the engine is warm, as this may crack the cylinder block.

### Non-freezing coolant mixtures

During the cold season the coolant must be mixed with anti-freeze, as pure water is liable to freeze and burst the cylinder block. Ethylene glycol is recommended as an anti-freeze fluid. For maximum security against freezing and rusting, the glycol dosage should be 40–50 %, i.e. 3.5–4.5 US quarts (3.5–4.5 liters) of glycol. Use if available glycol satisfying the requirements of the American Standard MIL–E–5559. This mixture can quite well be used all year round for two years at a time. If pure water is used during the summer season, a rustproofing agent should be added.

**NOTE!** When anti-freeze is added, it must first be mixed with a suitable quantity of water, as full circulation cannot take place until the thermostat opens. If pure anti-freeze is added, there is still a risk of the engine being damaged by ice if the anti-freeze does not mix with the engine coolant quickly enough.





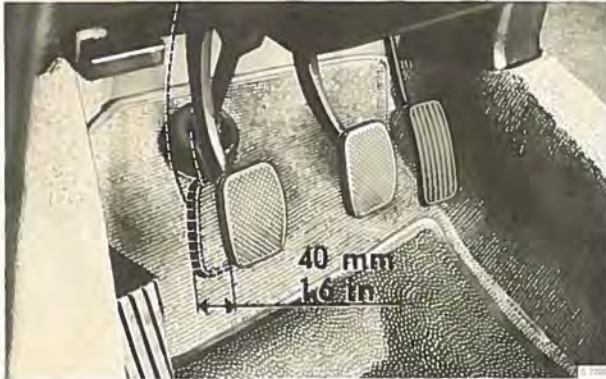

**Clutch pedal play**

### **CLUTCH, MANUAL TRANSMISSION**

The clutch is hydraulically operated by a master cylinder connected to the clutch pedal and a slave cylinder that acts on the clutch plate.

The master cylinder is provided with a container, which must be kept filled with brake fluid.

The clutch pedal should have a play of 1.6" (40 mm).

The play should be adjusted by an authorized Saab dealer.

### **MANUAL TRANSMISSION AND DIFFERENTIAL**

The transmission and differential are located beneath the engine and assembled to form an integral unit with the engine. Part of the transmission case serves as the engine

oil sump. The forward part of the transmission comprises a primary gear delivering power from the engine through the clutch to the actual gearbox, which is designed as an integral unit containing all shafts, gears, free wheel drive, differential and inner drive joints. All four forward gears are synchronized, while reverse gear is engaged by a sliding cogwheel. All cogs except the one for reverse gear are spiral cut and in constant engagement. Directions for shifting gear are given under "Driving instructions" on p. 25.

## DESCRIPTION AND CARE

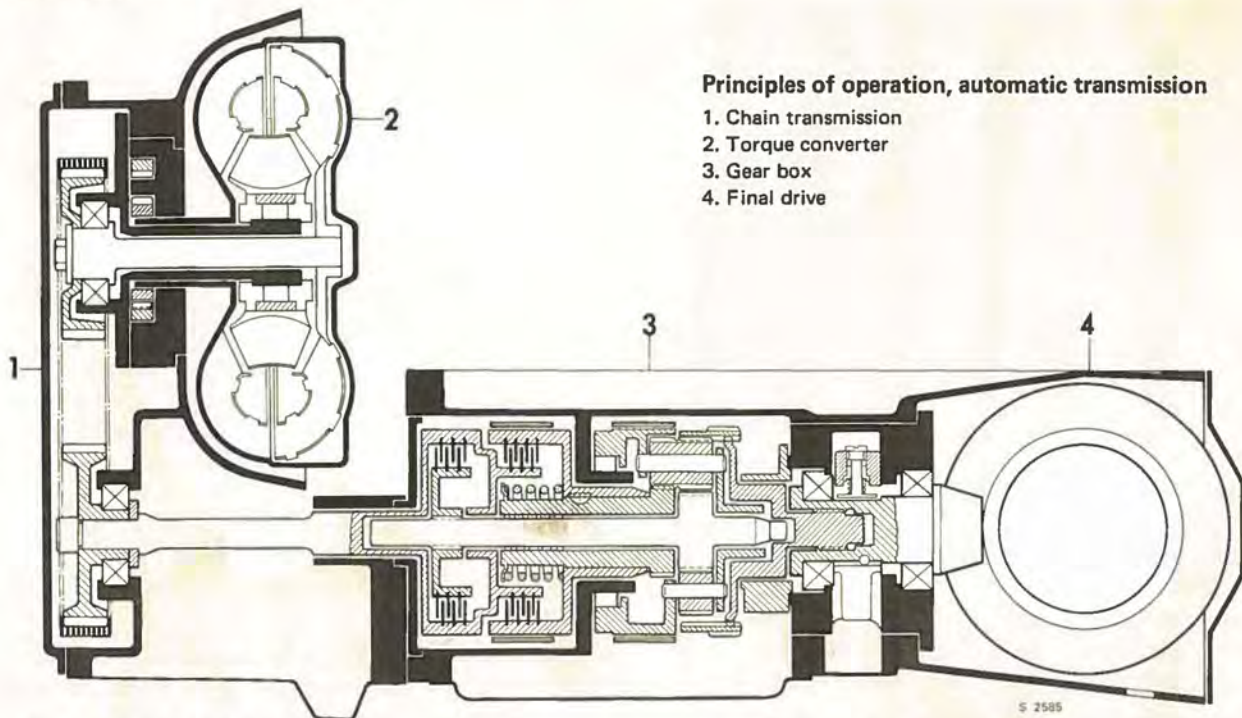

### Principles of operation, automatic transmission

1. Chain transmission
2. Torque converter
3. Gear box
4. Final drive

### AUTOMATIC TRANSMISSION

The automatic transmission features a hydrodynamic torque converter that smoothly transmits engine power to the gearbox. The latter incorporates a planetary gear train automatically regulated by clutches and brake bands, which in turn are operated by a hydraulic control system.

This system always engages the correct gear to match throttle opening and road speed.

The chain transmission and gearbox are lubricated with special automatic transmission oil, while the final drive is lubricated with standard transmission oil (see recommendations on p. 33).

## BRAKE SYSTEM

### General

The car has two mutually independent brake systems: the footbrake or driving brake, which is hydraulic and acts on all four wheels, and the handbrake or parking brake, which is mechanical and acts on the front wheels through drums in the disc brake hubs.

The footbrake system has two separate circuits. The master cylinder acts simultaneously but independently on each diagonally opposed pair of wheels, i.e. right front + left rear and left front + right rear. Thus if the system is damaged and brake fluid leaks out, braking power will be lost on one diagonal pair of wheels only, the other pair being unaffected. A leak can be detected by abnormally long pedal travel and by a tendency for the car to pull to the side that still has braking power on the front wheel.

The front wheel cylinders have a larger bore than the rear wheel cylinders, with the result that braking power is greater on the front wheels; this reduces the risk of the back wheels locking and skidding.

The footbrake system has a vacuum power assist from a cylinder connected to the engine induction manifold. When the brake pedal is depressed, it acts on the power assist which reinforces the pedal pressure and transmits the motion to the master cylinder.

The handbrake lever is located between the front seats

and its action is transmitted mechanically by cables.

In the instrument panel there is an indicator light that glows red if the handbrake is on or if the pedal goes too far down, e.g. because of brake fluid leakage. (Worn brake pads shown up in the form of high pedal pressure.)

If the brake warning light comes on when driving, the cause should be investigated immediately and any necessary repairs made by an authorized Saab dealer.

**Note!** Wear on the brake pad linings is automatically compensated by a gradual movement of the pads closer to the disc. The disc brakes are thus self-adjusting, so that when the linings are worn to the point of needing replacement, this does not show up direct in the form of an abnormally long pedal stroke. Instead, the signs to watch for are increasing pedal resistance and reduced braking effect. This form of warning has been achieved through the special design of the brake pad retainer springs, which prevents the pads from wearing clear down to the pressure plate and damaging the disc. The pedal stroke may however increase if the pads are worn beyond the replacement limit. **It is most important to check the thickness of the brake linings according to the directions given in the Service Book.** The pads are accessible for inspection after removal of the wheels. Minimum safe thickness of

## DESCRIPTION AND CARE

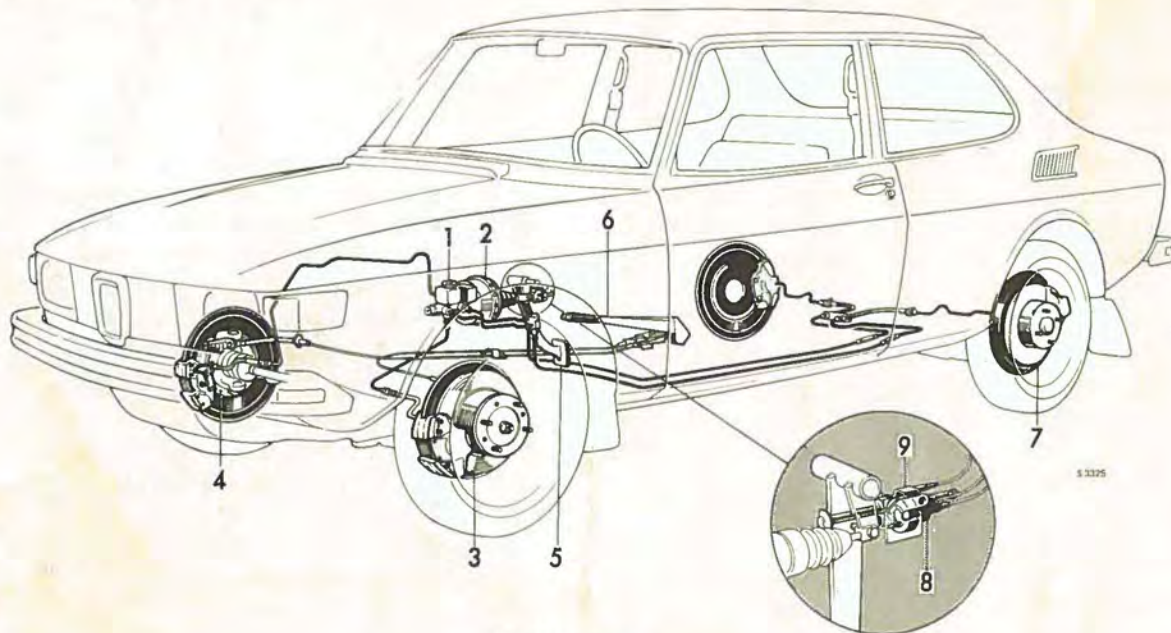

### Brake system

1. Master cylinder with brake fluid container
2. Power assist
3. Disc brake unit, front wheel
4. Brake shoes, handbrake
5. Brake pedal
6. Handbrake lever
7. Disc brake unit, rear wheel
8. Stop light contact
9. Brake warning contact switch

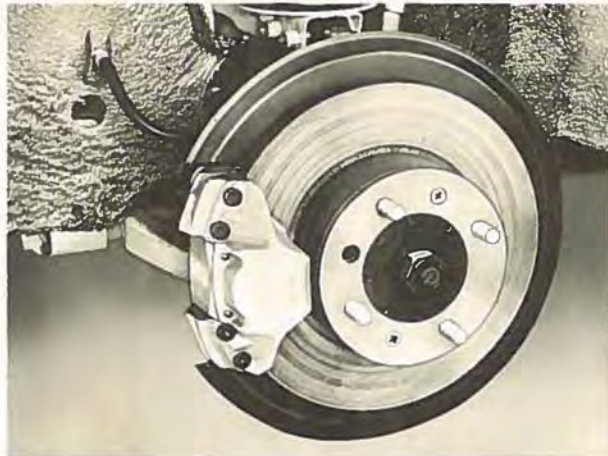

S 2346

**Front wheel brake, left**

the linings is 1/8". If any pad needs exchanging, the complete set of inboard and outboard pads on both front wheels or both back wheels must be renewed at the same time.

When having brakes reconditioned, insist that original Saab brake pads and shoes are fitted as replacements.

#### **Handbrake adjustment**

If the handbrake does not lock the front wheels at the sixth or seventh notch on the ratchet, it should be adjusted by an authorized Saab dealer.

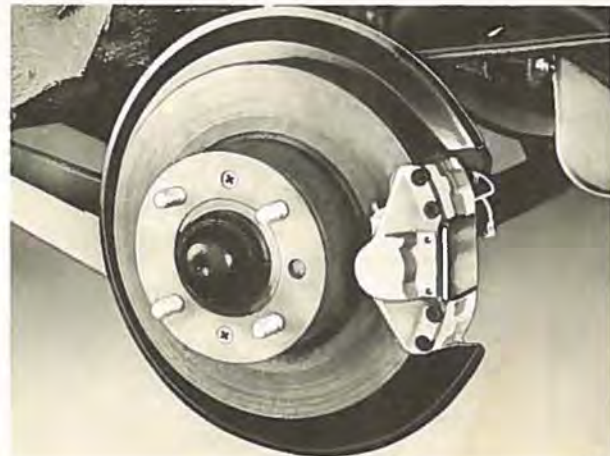

S 2347

**Rear wheel brake, left**

#### **Topping up brake fluid**

Check that the brake fluid container is well filled. Do not use inferior brake fluids, as these attack the rubber seals and endanger the functioning of the brake system. Even the best grade of brake fluid, however, eventually deteriorates through oxidation and absorption of water. The fluid should therefore be changed after 24,000 miles (40,000 km) or at intervals of two years. This should be done by an authorized Saab dealer. When changing or topping up brake fluid, make sure that fluid according to specification SAE J 1703a or SAE 70 R3 is used.

## DESCRIPTION AND CARE

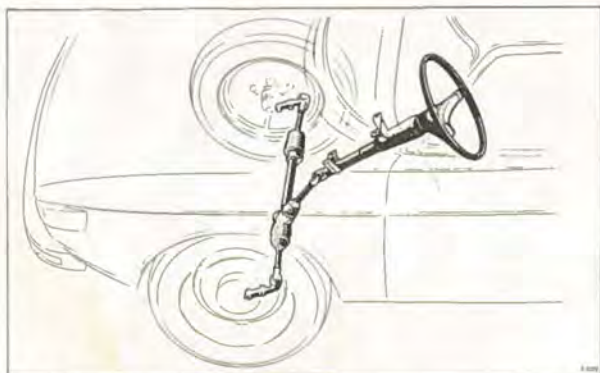

**Steering mechanism**

### STEERING MECHANISM

The steering column is of the automatically telescoping type.

Movements of the steering wheel are transmitted through an intermediate shaft to a pinion. This moves a rack, from the ends of which adjustable tie rods of equal length extend to the steering arms of the steering knuckle housings. The tie rods are attached to the rack and steering arms by ball joints.

**Note!** It is most essential that the steering gear is kept properly adjusted; all adjustments should be carried out by an authorized Saab dealer.

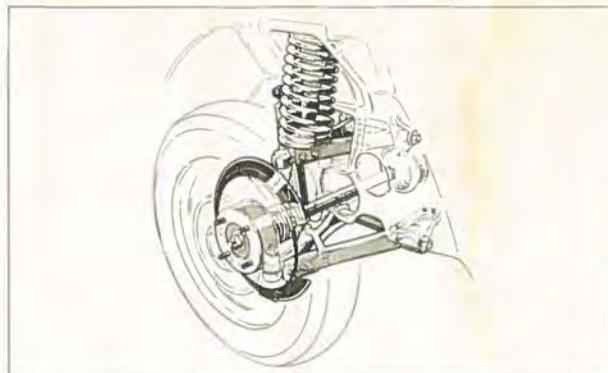

**Front suspension**

### SUSPENSION

The Saab 99 is equipped with coil springs and double-acting hydraulic shock absorbers of telescopic type. Rubber bushings and rubber insulating pads are used wherever possible to minimize road noise.

The front wheels are independently suspended. The steering knuckle housings are attached to the tie rods by permanently lubricated ball joints. The rear wheels are journaled on a straight rear axle attached to the body of the car by links mounted in rubber bearings.

If you have reason to suspect that anything is wrong with the suspension, you should have the car checked by an authorized Saab dealer.

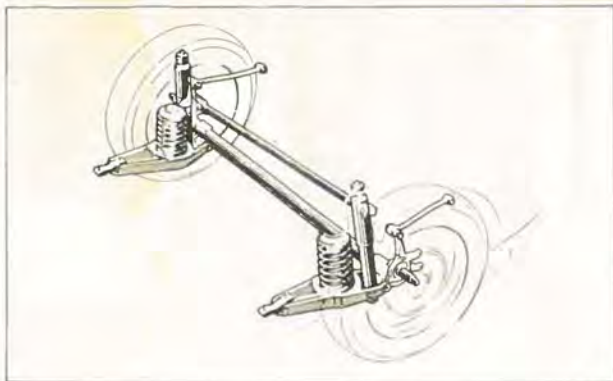

S 2038

Rear suspension



© 2004

Order of tightening wheel nuts

## WHEELS AND TIRES

### General

When a tubeless tire suffers a puncture, the air usually escapes very slowly, as the internal pressure tends to seal the hole in the synthetic rubber. This allows safe braking. Fitting and repair of tubeless tires should be entrusted to a specialist tire workshop.

The tires incorporate a profile depth indicator; when the tread pattern is worn down to 1/16" (1.6 mm), unpatterned cross bars appear. This is a signal that it is time to fit a new tire.

### Rotation of wheels and tires

The front-wheel drive causes the front tires to wear more than the rear tires. If it is desired to have the tires wear evenly, they should be changed around after a certain period of driving so that the least worn tires are at the front. When doing so, check that each tire in its new position revolves in the same direction as before: thus the left front tire should be changed with the left rear tire. By switching the tires in this manner, the working life of all four tires will remain approximately equal. The figure shows the sequence in which the wheel nuts are to be tightened.



## DESCRIPTION AND CARE

### JACK AND SPARE WHEEL

The tool bag and jack are stored under the floor of the trunk; the rear section of the floor lifts out easily. The spare wheel is carried upright in the trunk.

If you have to jack up the car, e.g. to change a wheel or inspect the brakes, locate the jack in one of the attachment points (front or rear) underneath the side members (see illustration).

1. Apply the handbrake. Slide the jack into the attachment point and crank it down until it touches the ground.
2. Before lifting, make sure that the upturned edge of the head of the jack is engaged inside the flange of the side member (see illustration) and that the whole of the foot is in contact with the ground. Slacken the wheel nuts slightly before lifting.
3. Crank up the jack until the wheel clears the ground.

Then unscrew the wheel nuts and take the wheel off.

To remove the hub cap, use the wheel nut socket wrench; insert the chisel-shaped end under the rim of the hub cap, press the wrench against the tire, and strike the free end with your hand.

If a garage jack is used, the lifting heads must be located under the reinforced parts of the underbody.

**Never crawl under the car when it is jacked up.**

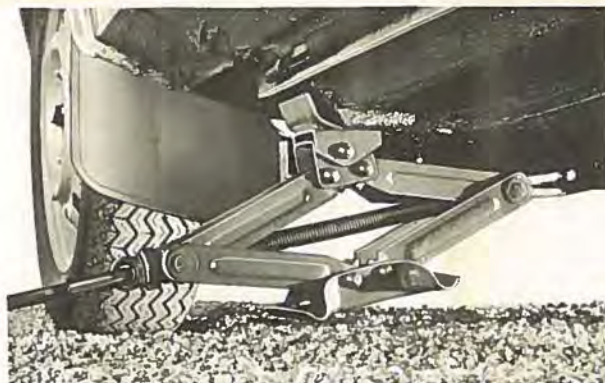

S 2039

1.



S 2040

2.



S 2041

3.

**Position of jack**

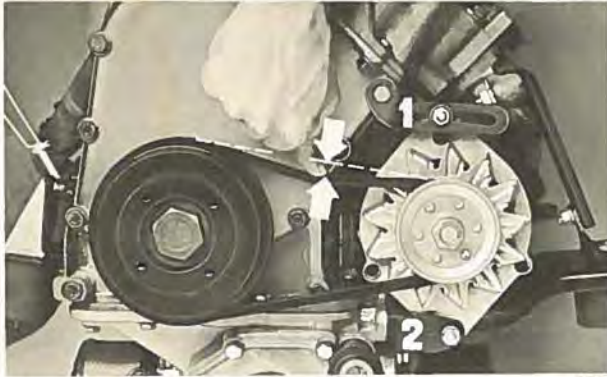

S 2350

**Alternator belt tension**

## ELECTRICAL SYSTEM

### Alternator

The electrical system works on alternating current supplied by an alternator. This is located on the right-hand side of the engine and driven by a V-belt from a pulley on the crankshaft. It is important to keep the proper tension. To tighten the belt if too loose, loosen the screws marked 1 and 2 in the illustration above and press the alternator outward. The belt should be tight enough so that it can be pressed down about 0.4" (10 mm) by a force of 3.5 lb (1.5 kp).

### Battery

The battery is one of the most important components of the car and should be given the most careful attention. Check the electrolyte level at least once a month in winter and every two weeks in summer; it should be 1/4"–1/3" (6–8 mm) above the tops of the cell plates. Top up as necessary, using distilled water only.

You should check the state of charge from time to time. Grease the post screws and clamps with vaseline to prevent oxidation, removing any old oxide deposits before applying the vaseline. Check that the battery is securely bolted to its shelf and that the post clamps and ground connections are tight.

Avoid prolonged heavy discharges. When making repeated

## DESCRIPTION AND CARE

attempts to start, give the battery a chance to recover between discharges.

### Warning

Do not misconnect the battery. If the cable connections are reversed, even momentarily, this will damage the diodes of the alternator. The insulated positive cable must be connected to the positive (+) post of the battery and the ground cable to the negative (-) post. If a spare battery is temporarily connected over the car battery, e.g. to assist starting, the connection must be made positive-to-positive and negative-to-negative. The battery must not be connected up to or disconnected from the electrical system of the car while the engine is running. During quick charging, the positive battery cable must be disconnected.

### \*Headlight adjustment

The headlights are mounted in the front grille. Each light has two adjusting screws which are accessible when the decor frame assembly has been removed. The upper screw is for vertical adjustment and the lower one for horizontal adjustment.

It is extremely important that the headlights are properly adjusted to give maximum night visibility without dazzling other drivers.

### Instrument illumination, control illumination and indicator lights

All the bulbs in the instrument assembly are mounted in bayonet fittings and are accessible from the back of the panel. The switch illumination bulb is located at the rear

\*This should be done by an authorized Saab dealer.

of the panel below the speedometer. The heater control and glove compartment illumination bulb is accessible when the cover in the left-hand wall of the glove compartment is removed.

### **Changing other light bulbs**

Loosen the fixing screws and remove the glass. Change the bulb and check that the new one is securely fitted and makes good contact. Wipe off the lamp and reflector and replace the glass, making sure that it fits tightly.

### **Fuses**

The electrical system is protected by 12 fuses including one spare for extra equipment if fitted. The fuses are

grouped in a box under the hood on the left wheel housing. The fuse holder is labeled to show the parts of the system protected by each fuse.

If a circuit goes dead but the fuse is intact, the cause may be faulty contact in the fuse holder or a cable connection. Check that the terminals are properly connected and not oxidized. When fitting a new fuse, see that it makes proper contact with the holder.

If the same fuse blows repeatedly, take the car to a Saab dealer as soon as possible for insulation testing of wiring and equipment.

# DESCRIPTION AND CARE

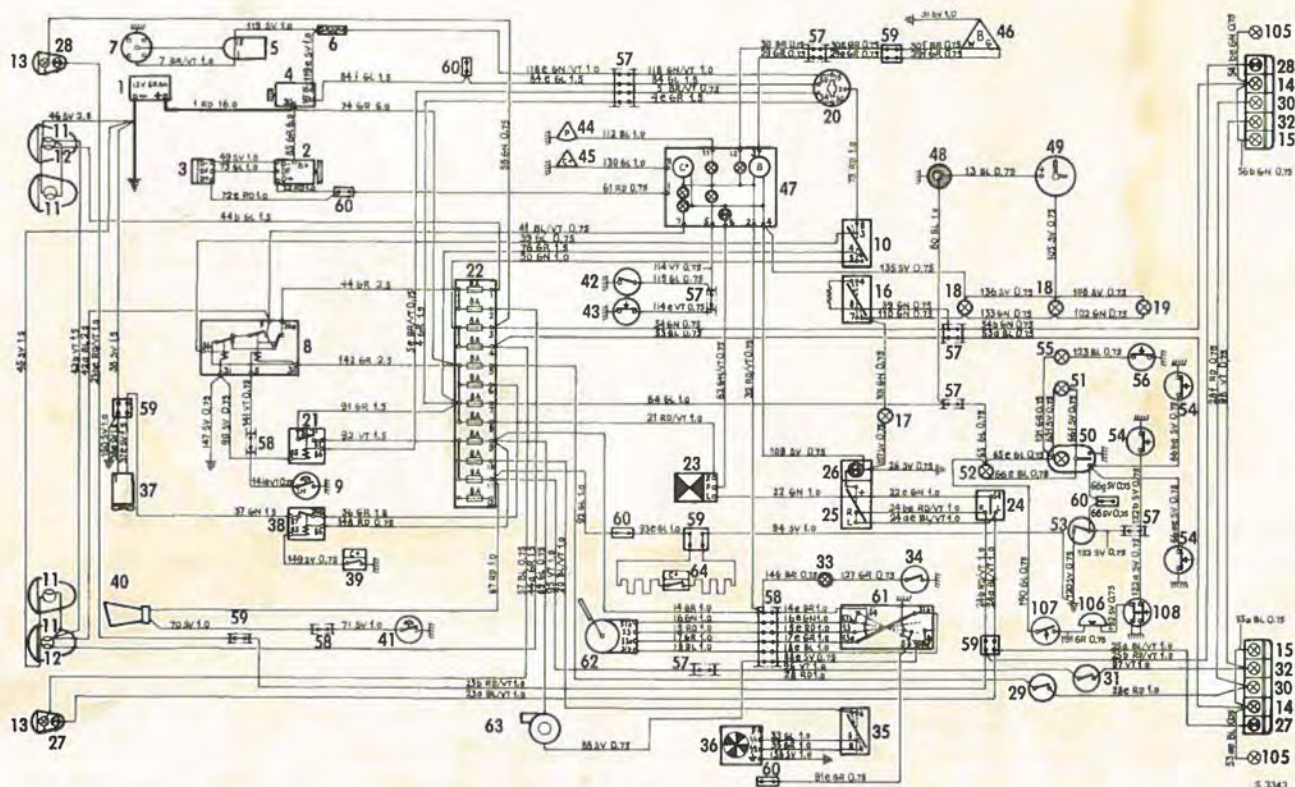

S 3343

Wiring diagram, Saab 99 2-door and 4-door models

## DESCRIPTION AND CARE

### COLOR CODE

BL	BLUE
BR	BROWN
GL	YELLOW
GN	GREEN
RD	RED
SV	BLACK
VT	WHITE
BL/VT	BLUE/WHITE
BR/VT	BROWN/WHITE
GN/VT	GREEN/WHITE
RD/VT	RED/WHITE

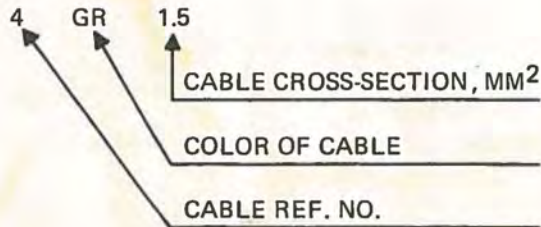

1. Battery
  2. Alternator
  3. Voltage regulator
  4. Starter motor
  5. Ignition coil
  6. Serial resistance
  7. Ignition distributor
  8. Lighting relay
  9. Headlight dimmer/flasher switch
  10. Light switch
  11. High beam
  12. Dimmed beam
  13. Front parking light
  14. Tail light
  15. License plate light
  16. Rheostat switch, instrument panel illumination
  17. Switch light
  18. Instrument panel light
  19. Glove compartment and heater control light
  20. Ignition
  21. Ignition relay
  22. Fuse box
  23. Direction indicator flasher unit
  24. Direction indicator switch
  25. Hazard warning signal switch
  26. Hazard warning signal repeater
  27. Direction indicator lights, L
  28. Direction indicator lights, R
- contd.

## DESCRIPTION AND CARE

29. Stop light contact
30. Stop lights
31. Backup light contact
32. Backup lights
35. Ventilator fan switch
36. Ventilator fan motor
37. Radiator fan motor
38. Radiator fan relay
39. Radiator fan thermostat contact
40. Horn
41. Horn contact
42. Brake warning contact
43. Handbrake contact
44. Oil warning contact
45. Temperature transmitter
46. Fuel tank gauge
47. Combination instrument: fuel gauge, fuel warning light, temperature gauge, oil warning light, ignition light, brake warning light, high beam indicator light, direction indicator repeater
48. Cigarette lighter
49. Clock
50. Dome light, side
51. Dome light, forward
52. Ignition switch light
53. Interior lighting switch
54. Door contact, interior lighting
55. Trunk light
56. Trunk light contact
57. 12-pin connector
58. 8-pin connector
59. 2-pin connector
60. 1-pin connector
61. Wiper system switch
62. 2-speed windshield wiper
63. Washer motor
64. Seat heating element with thermostat
90. Start inhibitor and backup light contact
91. Gear indicator light
92. Injection system control
93. Injection valve
94. Throttle contact
95. Temperature gauge (induction)
96. Pressure gauge
97. Temperature gauge (coolant)
98. Impulse contact (distributor)
99. Starter valve
100. Thermostat contact
101. Master relay
102. Pump relay
103. Fuel pump
105. Side position light (rear)
106. Buzzer
107. Key contact (buzzer)
108. 2-pin door contact

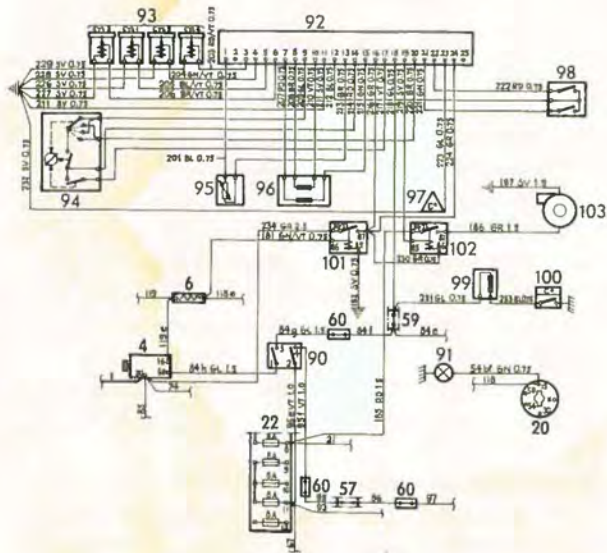

Detail of wiring diagram, injection engine with automatic transmission

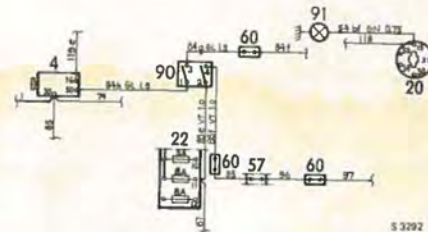

Detail of wiring diagram, injection engine with manual transmission



## DESCRIPTION AND CARE

### BODYWORK

#### Care of paintwork

To keep its gloss and finish, the paintwork needs proper care.

If the paintwork is damaged, e.g. by a flying stone, the spot can be cleaned and covered with air-drying touch-up paint. Half-pint cans of touch-up paint in the standard Saab colors can be purchased from your Saab dealer.

#### Washing

A new car should be washed frequently. It is best to use only water, as additives dry out the paintwork, but if water alone is not effective you can use a mild detergent. It is most important, however, to remove all traces of detergent from the paintwork, so hose the car down after washing, using plenty of water. **Never** wash the car in strong sunlight, and always wipe it dry with a clean chamois. If the car is left to dry in the sun, the lime in the water may leave streaks on the paintwork.

Windows are best cleaned with a chamois leather or soft linen cloth moistened in water.

#### Polishing

The general rule is that synthetic lacquer should not be polished with rubbing compound until it is absolutely necessary. In any event, it should not be polished until it has aged properly, which takes five or six months. Never use an abrasive polish on a new car. Only after some years may this be necessary to remove oxide and other deposits. The surface must always be thoroughly clean before polishing, otherwise it will be scratched.

A new car must not be waxed until the paintwork is at least five or six months old.

#### Maintenance of undercoating

In addition to its rustproofing properties, undercoating has an important soundproofing function. To preserve its effectiveness it should be regularly inspected and touched up if necessary. This applies particularly to the fenders and wheel housings, which are constantly exposed to abrasion by flying gravel, etc. If the composition has worn or flaked off, the steel must be thoroughly cleaned

and dried before a fresh coat is applied. The cleaning is best done with a scraper and a steel wire brush, followed by washing with gasoline. Apply the new coating thinly, as otherwise it may run off or fall off when dry.

### **Rustproofing**

Saab cars all undergo rustproofing treatment before leaving the factory. Despite this, there is still a risk of rust attack from the salts and other chemicals spread on the roads in wintertime. We therefore recommend inspection of the underbody and the doors once a year. This is particularly important in localities where cars are very much exposed to this kind of corrosion attack. Any necessary rustproofing treatment should be carried out by a reputable firm with a well-known rustproofing agent.

**Carpets** can be cleaned with a brush or sponge and carpet shampoo and then rinsed with water. Stubborn grease or oil stains can be removed with trichloroethylene.

### **Care of upholstery**

The cloth upholstery may be effectively cleaned with a cloth moistened in soap solution. Use lukewarm water. The plastic surfaces may be easily cleaned with lukewarm water and a synthetic detergent. A semistiff brush may be used.

### **Safety belts**

Clean the safety belts regularly with soap and lukewarm water.

## DESCRIPTION AND CARE

### TROUBLE SHOOTING, CARBURETED ENGINE

1. Engine fails to start even though cranked by starter at normal speed.

To get the engine started quickly, it is most important to follow the starting instructions.

- a. Check that there is fuel in the tank and that the charge indicator lamp lights up when the ignition is switched on.
- b. Check that the fuel pump is feeding fuel by disconnecting the fuel hose at the carburetor and letting the starter turn the engine over a few times (without depressing the accelerator pedal).
- c. Disconnect the cables from one spark plug at a time, and operate the starter. A powerful spark should then jump the gap when the cable is held close to the terminal on the plug.
- d. If only a feeble spark is obtained, or none at all, check whether the ignition cables are properly plugged into the distributor and ignition coil. Check the low-voltage connections of the ignition coil.
- e. Take off the distributor cap and wipe off any moisture. Check that the cap is not cracked and that the breaker points open when the engine is cranked. Clean the contact surfaces.
- f. If the engine has been cranked for some time without firing, fuel mixture may have flooded the cylinders and wetted the spark plugs. Unscrew the spark plugs and blow the cylinders clean by cranking the engine with the starter. Dry the plugs and check that the electrode gap is correct, or fit new plugs if available.

**2. Engine misfires, power is lost or engine runs roughly.****Check that:**

- a. None of the ignition cables has come loose.
  - b. None of the spark plugs is defective or in need of adjustment.
  - c. There is no short circuit in the ignition system.
  - d. There is good contact in the low-voltage connections of the ignition coil.
  - e. The carburetor has not iced up (may happen in damp weather). Remedy by switching the air pre-heater to winter setting.
  - f. The oil level in the carburetor damping cylinder is not too low.
  - g. The rubber diaphragm of the carburetor vacuum piston is intact.
- 3. Charge indicator lamp fails to light up when ignition is switched on. Possible reasons:**
- a. Battery is discharged or a battery cable has come

loose.

- b. The indicator light fuse has burnt out.
  - c. Bad cable contact at the ignition switch or charge indicator light.
  - d. Burnt-out light bulb.
  - e. Bad contact in wiring to voltage regulator.
- 4. Charge indicator lamp lights up when engine is running. Possible reasons:**
- a. Broken or slack alternator drive belt.
  - b. Defect in voltage regulator.
  - c. Defect in alternator.
- 5. Battery discharged. Possible reasons:**
- a. Slipping alternator drive belt.
  - b. Electrolyte level too low.
  - c. Frequent use of high-drain equipment, e.g. parking heater, combined with short journeys.
  - d. Defect in voltage regulator or alternator.

### TROUBLE SHOOTING, INJECTION ENGINE

#### 1. Engine fails to start even though cranked by starter at normal speed.

- a. Check that there is fuel in the tank and that the charge indicator lamp lights up when the ignition is switched on.
- b. Disconnect the cables from one spark plug at a time and operate the starter. A powerful spark should then jump the gap when the cable is held close to the terminal on the plug.
- c. If only a feeble spark is obtained, or none at all, check whether the ignition cables are properly plugged into connections of the ignition coil.
- d. Take off the distributor cap and wipe off any moisture. Check that the cap is not cracked and that the breaker points open when the engine is cranked. Clean the contact surfaces.
- e. If the engine has been cranked for some time without firing, fuel mixture may have flooded the cylinders and wetted the spark plugs. Unscrew the

spark plugs and blow the cylinders clean by cranking the engine with the starter. Dry the plugs and check that the electrode gap is correct, or fit new plugs if available.

#### 2. If the engine still refuses to start, check the fuel system.

- a. Check whether the fuse for the electric fuel pump (fuse No. 8) is intact. Scrape off any oxide deposits by rotating the fuse a few times in its holder. (It is usually possible to hear whether the fuel pump is working, as it runs for about one second when the ignition is switched on before stopping automatically.)
- b. Check whether the cable terminals are properly plugged into the pressure transmitter (located forward on the left wheel housing), the coolant temperature transmitter (located under the intake manifold) and the starter motor. These terminals are designed to fit one way only and must not be pushed in by force.

- c. Check the wiring connection to the fuel pump (accessible through a hatch in the floor of the trunk).
  - d. Check that none of the hoses in the fuel system has come loose.
  - e. A simple check on the operation of the injection system can be made as follows:  
Switch on the ignition (key to K). Open the hood and work the throttle control up and down. A clicking sound should then be heard from two of the injection valves. To cut in the other two injection valves, the engine must be cranked one revolution.
- 3. Engine misfires, power is lost or engine runs roughly.**  
**Check that:**
- a. None of the ignition cables has come loose.
  - b. None of the spark plugs is defective or in need of adjustment.
  - c. There is no short circuit in the ignition system.
  - d. There is good contact in the low-voltage connections of the ignition coil.
  - e. None of the injection valve cables has come loose.
- 4. Charge indicator lamp fails to light up when ignition is switched on. Possible causes:**
- a. Discharged battery or loose battery cable.
  - b. Burnt-out fuse for charge indicator light.
  - c. Bad wiring contact at ignition switch or charge indicator lamp.
  - d. Burnt-out light bulb.
  - e. Bad contact in wiring to voltage regulator.
- 5. Charge indicator lamp lights up when engine is running. Possible causes:**
- a. Broken or slack alternator drive belt.
  - b. Defect in voltage regulator.
  - c. Defect in alternator.
- 6. Battery is discharged. Possible reasons:**
- a. Slipping alternator drive belt.
  - b. Low electrolyte level in battery.
  - c. Frequent use of high-drain equipment, e.g. parking heater, combined with short journeys.
  - d. Defect in voltage regulator or alternator.

## DRIVING WITH A TRAILER

A special towing attachment rated for a maximum trailer weight of 2,400 lb (1,100 kg) is available as an optional accessory for the Saab 99. Bolt holes are already provided to facilitate mounting of the attachment.

A car with automatic transmission must be fitted with a transmission oil cooler before it can be used to tow a trailer. A suitable cooler is available as an accessory for the Saab 99 Automatic.

It is inadvisable for several reasons to hook an excessively heavy trailer to a car, and the following points should therefore be borne in mind:

1. Legal restrictions on towing speed, trailer weight and trailer braking equipment in the country concerned must of course be complied with.
2. For reasons of road safety the weight of the trailer should not exceed 2,400 lb (1,100 kg) on roads with normal gradients. On roads with steep gradients (12 % or more) the weight should not exceed 1,900 lb (850 kg). These weights refer to trailers equipped with adequate brakes; unbraked trailers should not weigh more than 1,100 lb (500 kg).
3. If the car has an automatic transmission, position 1 should be selected for towing on steep gradients.
4. When towing a trailer, avoid gradients of 15 % or more, as in such conditions the weight on the front driving wheels is so low that they may lose traction and leave the car stalled. For the same reason, the handbrake effect may be so reduced that the car and trailer cannot be held stationary on an uphill grade by the hand-

## MOTORING ABROAD

brake alone without the wheels starting to slide. When driving with a trailer on very long hills, you can help the engine to keep cool by turning on the fresh air heater and running the ventilator fan at full speed.

5. The load distribution in the trailer is most important. In a two-wheeled trailer the load should be placed low down and concentrated as far as possible over the wheels. The trailer should be loaded in such a way that the downward force on the tow hook of the car is about 110 lb (50 kg), i.e. about the weight that one man can normally lift. The maximum load carried aboard the towing vehicle must be reduced by the same amount.
6. When driving with a trailer, always make allowance for the altered handling characteristics and longer stopping distance. The brakes, suspension and shock-absorbing equipment of the trailer are very important in this respect.

### MOTORING ABROAD

Before setting out on a journey abroad, for instance to Europe, we suggest that you ask your local Saab dealer for a copy of the booklet "SAAB Europa Service", which contains useful hints about foreign travel and a list of service facilities abroad.

**DIMENSIONS, ETC**

Overall length incl. bumpers . . .	14' 4" (4370 mm)
Overall width . . . . .	5' 6.5" (1690 mm)
Overall height (empty) . . . . .	4' 8.5" (1440 mm)
Road clearance (curb weight) . . .	6.75" (175 mm)
Track, front wheels . . . . .	4' 6.75" (1390 mm)
Track, back wheels . . . . .	4' 7.25" (1400 mm)
Wheelbase . . . . .	8' 1.5" (2473 mm)
Turning radius . . . . .	17' 1" (5.2 m)

**Weight:**

Curb weight . . . . . 2460 – 2650 lb (1115 – 1200 kg)

**Gross vehicle weight rating:**

2-door model . . . . .	3440 lb (1560 kg)
4-door model . . . . .	3510 lb (1590 kg)

**Gross axle weight rating:**

Front axle . . . . .	1940 lb (880 kg)
Rear axle . . . . .	1770 lb (800 kg)

**Vehicle capacity weight:**

Without air conditioning . . .	900 lb (410 kg)
With air conditioning . . . . .	860 lb (390 kg)

Weight distribution by curb weight . . . . . front 61–63%

Weight distribution by gross vehicle weight rating . . . . . front 52–55%

Trunk volume (SAE) . . . . . 11.8 cu.ft (0.347 m<sup>3</sup>)

Max. roof rack load . . . . . 220 lb (100 kg)

Max. trailer weight . . . . . 2400 lb (1100 kg)

**1.85 L CARBURETED ENGINE**

Type . . . . . 4-cyl., 4-stroke with overhead camshaft

Power rating, SAE net at 5200 rpm . . . . . 65 kw (88 hp)

Max. torque at 3000 rpm . . . . . 108 ft.lb. (147 Nm)

Compression ratio . . . . . 9.0:1

No. of cylinders . . . . . 4

Cylinder bore . . . . . 3.425" (87.0 mm)

Stroke . . . . . 3.071" (78.0 mm)

Cylinder volume . . . . . 113.1 cu.in. (1854 cc)

**Valve clearance, warm or cold engine:**

Inlet . . . . . 0.006–0.012" (0.15–0.30 mm)

Outlet . . . . . 0.014–0.020" (0.35–0.50 mm)

Order of firing (cyl. 1 farthest to the rear of the car) . . . . . 1–3–4–2

Engine idling speed . . . . . 800–850 rpm

Oil volume . . . . . 4 US qt. (3.5 lit)



## TECHNICAL DATA

### 1,85 L INJECTION ENGINE

Type	4-cyl., 4-stroke with overhead camshaft
Power rating, SAE net at 5200 rpm	71 kw (97 hp)
Max. torque, at 3000 rpm	105 ft.lb. (143 Nm)
Compression ratio	9.0:1
No. of cylinders	4
Cylinder bore	3.425" (87.0mm)
Stroke	3.071" (78.0 mm)
Cylinder volume	113.1 cu.in. (1854 cc)
Valve clearance, warm or cold engine:	
Inlet	0.006–0.012" (0.15–0.30 mm)
Outlet	0.014–0.020" (0.35–0.50 mm)
Order of firing (cyl. 1 farthest to the rear of the car)	1–3–4–2
Engine idling speed	800–850 rpm
Oil volume	4 US qt. (3.5 lit)

### FUEL SYSTEM, INJECTION ENGINE

Fuel tank capacity	11.8 US gal (45 lit)
Fuel injection:	
Type	Jetronic
Make	Bosch

### FUEL SYSTEM, CARBURETED ENGINE

Fuel tank capacity	11.8 US gal (45 lit)
Horizontal carburetor	Zenith-Stromberg 175 CD–2SE
Fuel pump, mechanical	AC Delco type Unitac

### COOLING SYSTEM

**Note! The radiator must not be screened off.**

Coolant volume incl. heating system	9 US quarts (8.5 lit.)
Thermostat opens at	185° F (85° C)

### MANUAL TRANSMISSION WITH DIFFERENTIAL

Type	4-speed all-synchromesh box with final drive and differential
Oil volume	3 US qt (3 lit)
Grade of oil	See recommendation on p. 33
Clutch (hydraulic operation)	single dry plate with spring-loaded hub

## TECHNICAL DATA

### Gear ratios, total

1st gear	13.6:1
2nd gear	8.6:1
3rd gear	5.8:1
4th gear	4.1:1
Reverse gear	13.6:1
Final drive ratio	4.22:1

### Road speeds at 1000 rpm engine speed:

1st gear	5.2 mph (8.4 km/h)
2nd gear	8.3 mph (13.3 km/h)
3rd gear	12.2 mph (19.6 km/h)
4th gear	17.7 mph (28.5 km/h)
Reverse gear	5.2 mph (8.4 km/h)

### AUTOMATIC TRANSMISSION

Oil volume, automatic transmission	8.5 US quarts (8lit)
Grade of oil	See recommendation on p. 33
Oil volume, final drive	1.3 US quart (1.25 lit)
Grade of oil	See recommendation on p. 33

### Torque ratios, total:

D	18.92–4.15
2	18.92–6.01
1	18.92–9.90
R	16.55–8.66

Torque converter ratio	1.91:1–1:1
Primary gear ratio	1.09:1
Gear ratios: 1st gear	2.39:1
2nd gear	1.45:1
3rd gear	1:1
Reverse gear	2.09:1
Final drive ratio	3.82:1
Idling speed	800–850 rpm with gear selector lever at P or N

### Shift speeds:

		Upshift speed	
		1st–2nd	2nd–3rd
Full throttle	about	25 mph (45 km/h)	about 45 mph (70 km/h)
"Kick-down"	—"–"	35 mph (60 km/h)	—"–" 65 mph (105 km/h)
		Downshift speed	
		3rd–2nd	2nd–1st
Full throttle		—	—
"Kick-down"	about	55 mph (90 km/h)	about 25 mph (40 km/h)

## TECHNICAL DATA

### BRAKE SYSTEM

Make	ATE
Footbrake	hydraulic disc brakes with power assist, two-circuit system serving diagonally opposed pairs of wheels
Disc diameter	10.63" (269.5 mm)
Friction areas:	
Front wheels	188 sq.in. (1215 cm <sup>2</sup> )
Rear wheels	170 sq.in. (1095 cm <sup>2</sup> )
Total	358 sq.in. (2310 cm <sup>2</sup> )
Handbrake	mechanical drum brake acting on front wheels

### SUSPENSION

Suspension elements, front and rear	coil springs
Total spring compression/elongation:	
Front	6,33" (160 mm)
Rear	7.1" (180 mm)

### SHOCK ABSORBERS

Type	hydraulic, telescopic
Max. working stroke fitted to car:	
Front	3.6" (91 mm)
Rear	6.2" (158 mm)

### STEERING MECHANISM

Steering gear	rack-and-pinion type
Wheel turns lock-to-lock	3 1/2

### WHEELS AND TIRES

Type	disc wheels
Rim dimensions	4 1/2 J FHA x 15"
Tires	tubeless
Tire dimensions (radial)	155-SR 15
Tire pressures:	
Light load, front and rear	27 psi (1.9 bar)
Heavy load, front and rear	30 psi (2.1 bar)
The pressures refer to cold tires.	

### Front wheel alignment

Toe-in, measured at rims	0 ± 0.04" (0 ± 1 mm)
Camber	0.75° ± 0.25°
Caster	0.75° ± 0.25°
King pin inclination	11.5° ± 1°

### ELECTRICAL SYSTEM

Voltage	12 V
Battery capacity	60 Ah
Starter	0.7 kW (1 hp)
Alternator, max. charging current/voltage	55 amp/14 V (for carbureted engines 35 amp/14 V)
Distributor contact gap	0.012-0.016" (0.3-0.4 mm)
Order of firing (cyl. 1 farthest back to the rear of the car)	1-3-4-2

## TECHNICAL DATA

### Spark plugs

Type	Champion N-11Y NGK BP-6E AC 44.X.L.S. Bosch W 175 T30 Bosch WG 160 T 30 Autolite AG 22
Thread	M 14
Thread length	0.7" (18 mm)
Electrode gap	0.025" (0.6 mm)

### Ignition advance, carbureted engine:

Basic setting	9° BTDC
---------------	---------

### Ignition advance, injection engine:

Basic setting	5° BTDC
---------------	---------

### Fuses

Number	12
Rated current	8 amp

### Light bulbs

	Power	SAE Trade No.	Qty.
Headlight, Sealed Beam, high beam	37.5W	4001	2
Headlight, Sealed Beam, high and low beam	37.5/50W	4002	2
Front direction indicator	21W	1073	2
Front parking light	5W	67	2

### Rear direction

indicator, stop and back-up lights	21W	1073	6
Tail light and number plate light	5W	67	4
Side position light, rear	4W	S7	2
Dome light	10W	Cartridge bulb	1
Trunk light	5W	Cartridge bulb	1
Heater control illumination	1.2W	Glass fitting	1
Ignition switch illumination	2W	Miniature bulb	1
Rear view mirror light	5W	Miniature bulb	1
Instrument and indicator lights	1.2W	Glass fitting	8
Hazard warning signal switch	1.2W	Glass fitting	1
Switch illumination	1.2W	Glass fitting	1

### TOOL KIT

Jack in bag with crank handle

Tool kit in bag, comprising:

- Adjustable wrench
- Combination pliers
- Phillips screwdriver
- Screwdriver
- Socket wrench for wheel nuts
- Socket wrench for spark plugs
- Hexagon spanner for removing

## ALPHABETICAL INDEX

Air cleaner . . . . .	43, 45	Chassis No., location of . . . . .	6
Air pressure, tires . . . . .	34, 74	Choke . . . . .	11, 24
Alternator . . . . .	57, 74	Cleaning	
Alternator drive belt tension . . . . .	57	Air filter insert . . . . .	43, 45
Automatic transmission . . . . .	26, 30	Carpets . . . . .	65
		Safety belts . . . . .	65
		Upholstery . . . . .	65
Back seat . . . . .	22	Clutch . . . . .	49, 72
Back seat heating and ventilation controls . . . . .	16	Clutch fluid	
Battery		Container . . . . .	33
Capacity . . . . .	74	Grade . . . . .	38
Charge, state of . . . . .	57	Clutch pedal play . . . . .	49
Charging, quick . . . . .	58	Cold start device . . . . .	11, 24
Connecting and disconnecting . . . . .	58	Coolant temperature gauge . . . . .	13
Electrolyte level . . . . .	33, 57	Cooling system	
Brake fluid		Anti-freeze mixture . . . . .	47
Checking, changing, filling . . . . .	33, 38, 53	Coolant change . . . . .	47
Container . . . . .	33	Description . . . . .	47
Grade . . . . .	38, 53	Topping up . . . . .	33, 47
Brake system		Crankcase ventilation . . . . .	40
Description . . . . .	51-53		
Technical data . . . . .	71	Damaged paintwork . . . . .	64
Brakes . . . . .	28, 33	Dimensions and weights . . . . .	71
		Dipstick, engine . . . . .	32
Carburetor . . . . .	46	Dipstick, automatic transmission . . . . .	36
Carpets . . . . .	65	Distributor . . . . .	40

# ALPHABETICAL INDEX

Door locks . . . . .	7	Fuel . . . . .	32
Drain cocks, coolant . . . . .	48	Fuel filter . . . . .	42, 44
Drain plugs . . . . .		Fuel gauge . . . . .	13
Engine . . . . .	35, 37	Fuel pump . . . . .	42, 44
Transmission . . . . .	35, 37	Fuel system . . . . .	42, 44
Driving economy . . . . .	29	Fuel tank, capacity . . . . .	72
Driving instructions . . . . .	24	Fuses . . . . .	59, 75
Driving on slippery roads . . . . .	29	Gear positions . . . . .	25, 26
Driving with a trailer . . . . .	70	Gear shift lever lock . . . . .	9
Driving with an open trunk lid . . . . .	31	Gear shifting . . . . .	25
Electrical system . . . . .	57	Glove compartment lock . . . . .	8
Engine . . . . .	40 71, 72	Glycol . . . . .	47
Engine No., location of . . . . .	6	Greasing . . . . .	35–39
Engine oil . . . . .	32	Handbrake . . . . .	17, 53
Ethylene glycol . . . . .	47	Hazard warning signal . . . . .	11, 12
Fresh air blowers . . . . .	11, 16	Headlights . . . . .	
Front seats, adjustment . . . . .	20	Alignment . . . . .	58
Front wheel alignment . . . . .	74	Control switch . . . . .	12
Frozen locks . . . . .	30	Dimmer and flasher switch . . . . .	12
		Heating and ventilation controls . . . . .	11, 14–16
		Hood lock . . . . .	11, 17
		Horn control . . . . .	11

# ALPHABETICAL INDEX

Ignition timing . . . . .	41	Manual transmission . . . . .	25
Ignition switch and gear lever lock . . . . .	9	Mirrors . . . . .	19
Ignition switch illumination . . . . .	17	Motoring abroad . . . . .	70
Indicator lights		Odometer . . . . .	13
Changing bulbs . . . . .	58	Oil, changing and filling	
Description . . . . .	13	Engine . . . . .	32
Instrument panel . . . . .	13	Transmission . . . . .	33
Instrument panel illumination . . . . .	10, 11	Oil dipstick . . . . .	32
Interior lighting . . . . .	17	Oil filter . . . . .	32
Jack . . . . .	56	Paintwork . . . . .	64
Keys . . . . .	7	Parking light switch . . . . .	11, 12
Kick-down . . . . .	27	Polishing . . . . .	64
Light bulbs . . . . .	58, 59, 75	Preheater . . . . .	46
Lights . . . . .	17	Quick charge, battery . . . . .	58
Locks . . . . .	7, 8, 9	Radiator and radiator fan . . . . .	47
Lubrication		Repairs to paintwork and underbody coating	64
Chart . . . . .	39	Rustproofing . . . . .	64
Instructions . . . . .	35–39	Safety belts . . . . .	22
Table . . . . .	38		

**SAAB-SCANIA**  
of America, Inc.

788734 USA Aug. 1971



## ALPHABETICAL INDEX

Seats			
Back	22	Trouble shooting	65–69
Front	20	Trunk	22
Shock absorbers	54, 74	Trunk lock	8
Slippery roads	29		
Spark plugs	40, 75	Undercoating	64
Spare wheel	56	Upholstery	65
Speedometer	13		
Starting	24	Valve clearance	71, 72
Steering characteristics	28	Ventilation and heating controls	11, 14–16
Steering mechanism	54, 74	Ventilation, crankcase	40
Suspension	54, 74	Ventilator fan switch	11, 14
Switches	11–14		
		Warning and indicator lights	13
Technical data	71	Warning signal, hazard	11, 12
Temperature gauge, coolant	13	Washing	64
Thermostat, cooling system	47	Weights and dimensions	71
Tire pressures	34, 74	Wheels and tires	
Tires	28, 55, 74	Changing	56
Tool kit	75	Description	28, 56, 74
Towing	31	Rotation	55
Trailer, driving with	70	Windshield washer container	34
Transmission and differential, manual	49, 72	Windshield washers and wipers	11, 14
Transmission, automatic	50, 73	Winter tires	30
Transmission oil	33	Wiring diagram	60

Produced and edited by Technical Publications  
Saab—Scania, Trollhättan, Sweden  
Printed in Sweden by AB Reprona, Lysekil 1971  
Endast för spridning utomlands.